

- *Three phase control panel
- *Coffret de commande triphasé
- *Armario de maniobra trifasico
- *Quadro elettrico trifase
- *PN-Schaltung dreiphasig
- *Quadro electrico trifasico

- Wiring diagram
- Schéma de branchement
- Esquema de conexion
- Schema di collegamento
- Anschluss schema
- Esquema de ligacoes

Calibrer le disjoncteur en fonction de la puissance de la pompe
 Adjust the circuit breaker according to the power of the pump
 Ajustar el valor de corriente segun el consumo de la bomba
 Regolare il disgiuntore in funzione della potenza della pompa
 Den Schalter gemäß der Kraft der Pumpe eichen
 Calibrar o disjuntor em função da potência da bomba

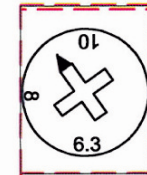

ALIMENTACION 3x400V+N

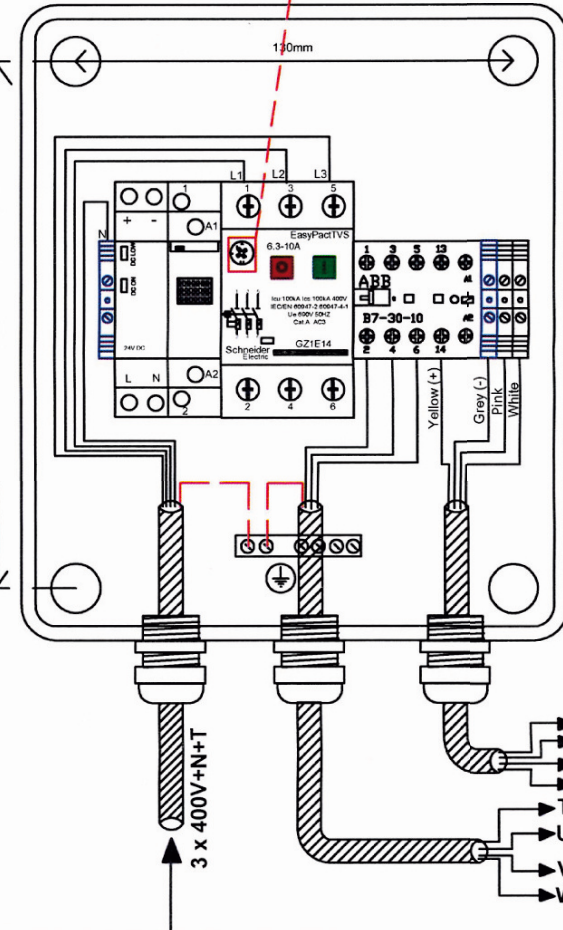
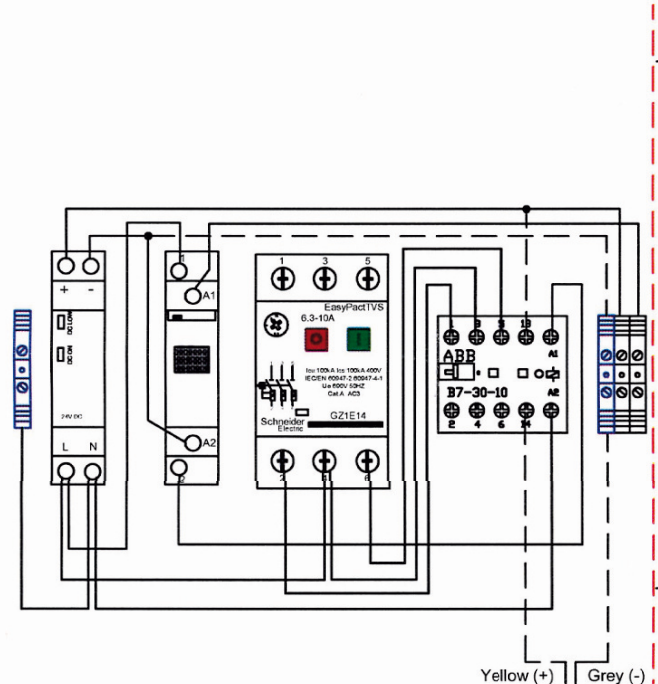
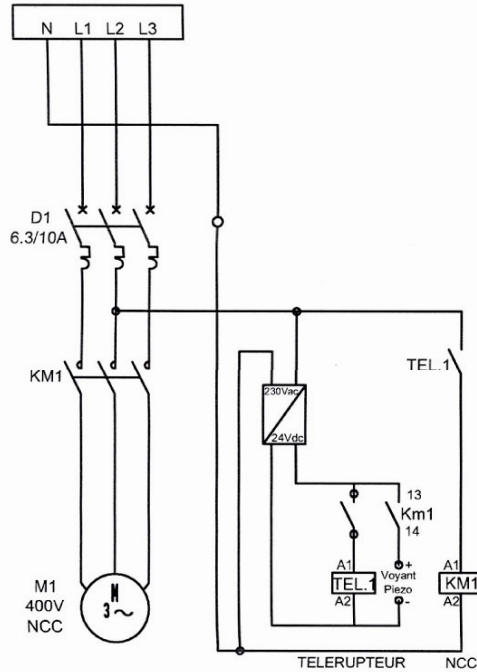

Pulsador Piezoeléctrico
 Rosa / Pink
 Blanco / White
 Amarillo / Yellow
 Gris / Grey

M
 400V
 3Ph+T

65498E203-04 03.19

ESQUEMA ARMARIO MANIOBRA NCC
65498 - 66044

