

## Installation and Instruction Manual

### WHIRLPOOLS FOR INGROUND INSTALLATION



AND TECHNICAL PACKAGE ELS / PWW

<b>1. Technical Drawings</b>		
1.1	Strato 2.0 .....	Page 3
1.2	Strato 2.3 .....	Page 4
1.3	Wave 2.0 .....	Page 5
1.4	Roman 195 .....	Page 6
1.5	Roman 225 .....	Page 7
<b>2. General Information / Requirements on site</b>		
2.1	Specific use and purpose .....	Page 8
2.2	Subsoil/Foundation .....	Page 8
2.3	Power supply .....	Page 8
2.3	Fresh water .....	Page 9
2.4	Waste water .....	Page 9
2.5	Delivery .....	Page 9
2.6	Noise insulation .....	Page 9
<b>3. Installation Description</b>		
3.1	Installation diagram .....	Page 10
3.2	Connections to the pool .....	Page 11
3.3	Description technical Package ELS .....	Page 12
3.4	Description technical Package PWW .....	Page 13
<b>4. Noise Reduction</b>		
4.1	Noise Insulation Precautions .....	Page 14
4.2	Installation with special noise insulation precautions .....	Page 14
4.3	Installation without special noise insulation precautions .....	Page 15
<b>5. Installation Example</b>		Page 16
<b>6. Start-up and Operation</b>		
6.1	Switching the power supply on and off for the first time .....	Page 18
6.2	Operation of the massage jets .....	Page 19
<b>6.3</b>	<b>Operating the digital display</b> .....	Page 20
6.3.1	The main screen .....	Page 20
6.3.2	Setting the temperature .....	Page 22
6.3.3	The Spa screen (user functions) .....	Page 22
6.3.4	General Keys .....	Page 23
6.3.5	Screenshot: Settings .....	Page 24
6.3.6	Settings for the temperature ranges .....	Page 25
6.3.7	Filling the spa .....	Page 25
6.3.8	Filtration .....	Page 28
6.3.9	Frost protection .....	Page 28
6.3.10	Auxiliary control panel (s) .....	Page 29
6.3.11	Locking the operating keys .....	Page 29
6.3.12	The Fault Log .....	Page 30
6.3.13	Informations .....	Page 31
6.3.14	The cleaning cycle .....	Page 32
6.3.15	Language .....	Page 32
6.3.16	General Information .....	Page 33
6.3.17	Error messages for heating .....	Page 34
6.3.18	Error messages for sensors .....	Page 35
6.3.19	Error messages for the main system .....	Page 36
6.3.20	Things to remember .....	Page 37
6.4	Audiosystem .....	Page 38
<b>7. Care and maintenance</b>		
7.1	Care Manual Whirlpool covers .....	Page 39
7.2	Care of headrest and pillows .....	Page 40
7.3	Water maintenance .....	Page 41
<b>8. Instructions for bathing</b>		Page 43
<b>9. Schematics</b>		Page 44
<b>10. Checklist</b>		Page 46

## 1. Technical Drawings

### 1.1 Strato 2.0 Inground Whirlpool

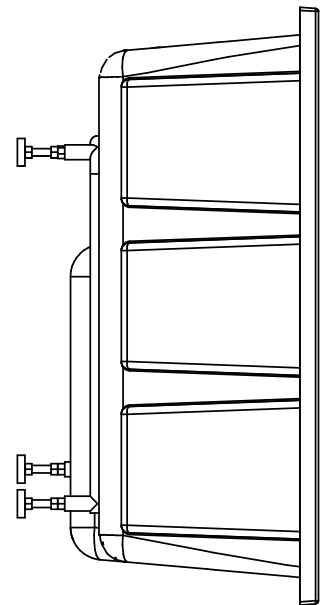
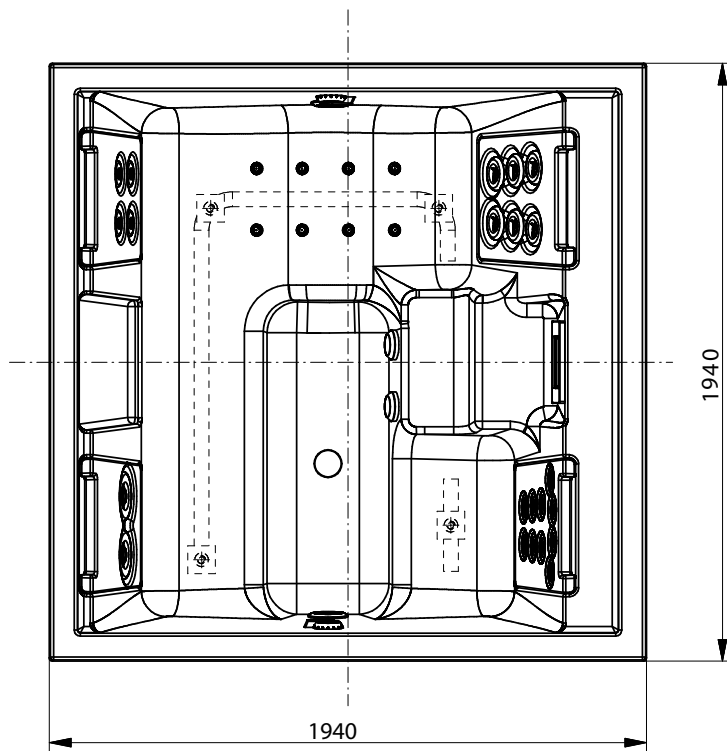
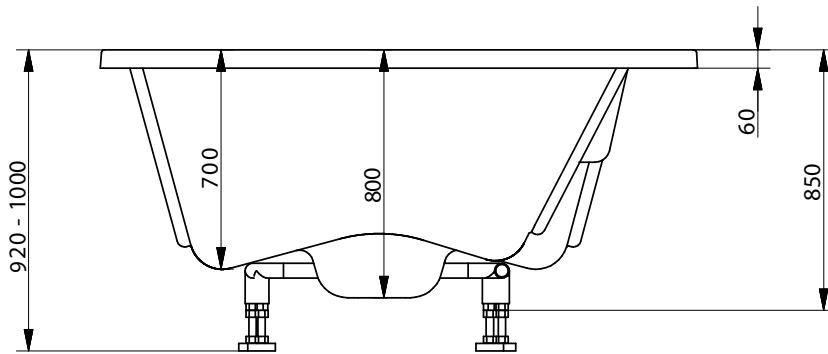

#### Information:

Additional information is available from our technical customer service department. We reserve the right, to perform production changes and improvements without prior notice In terms of technical progress.

## 1.2 Strato 2.3 Inground Whirlpool

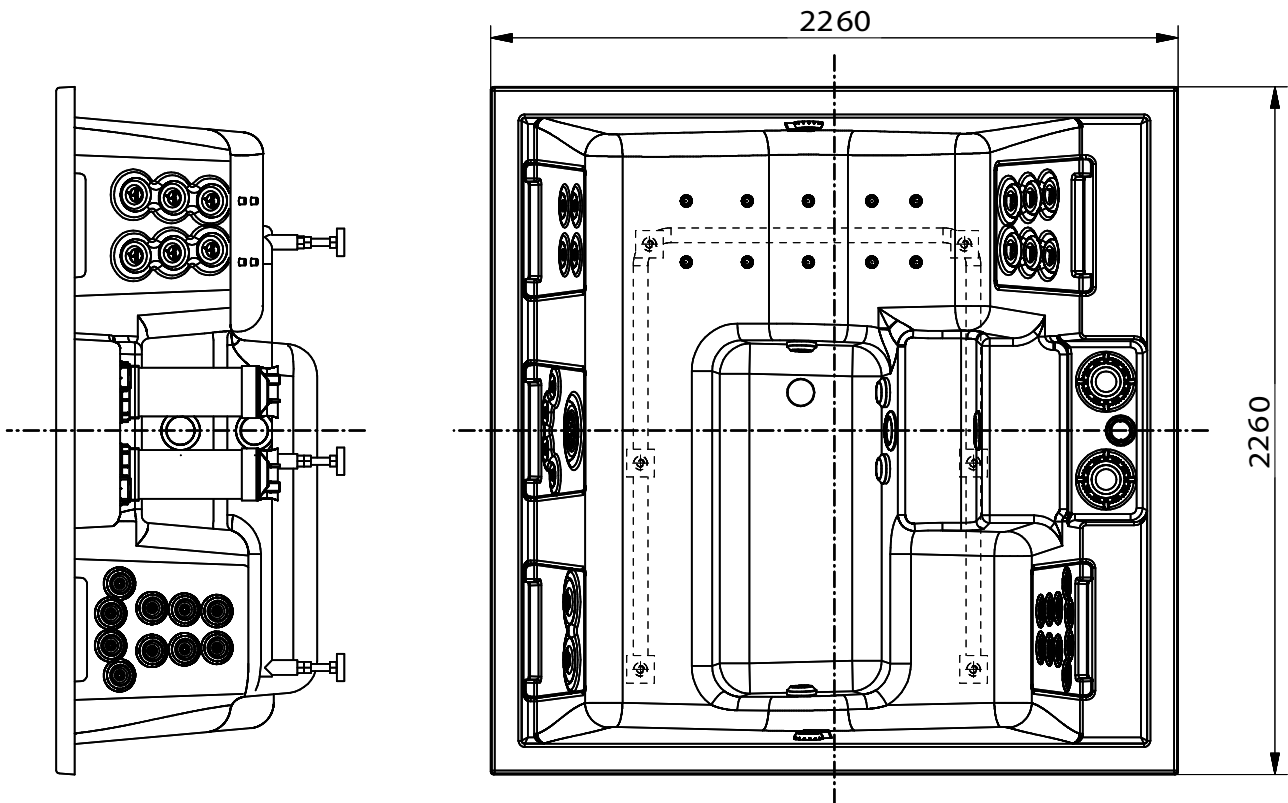
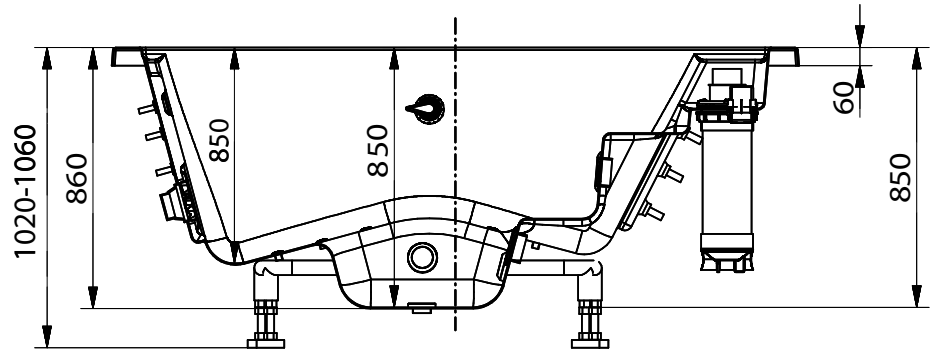

## 1.3 Wave 2.0 Inground Whirlpool

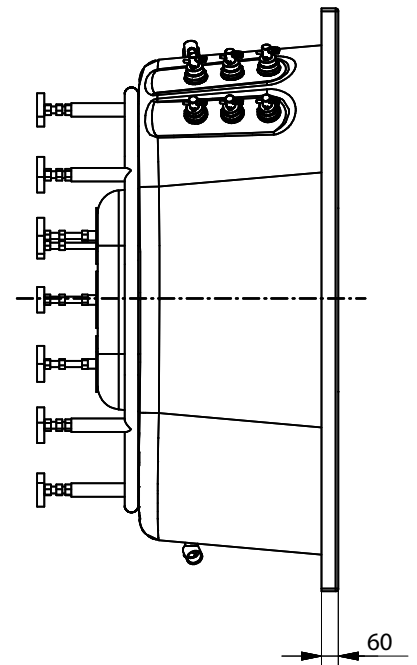
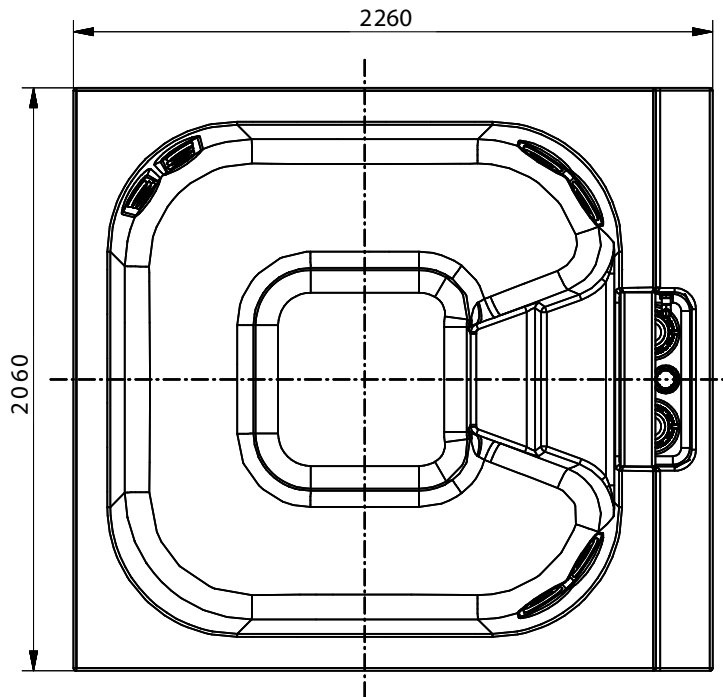
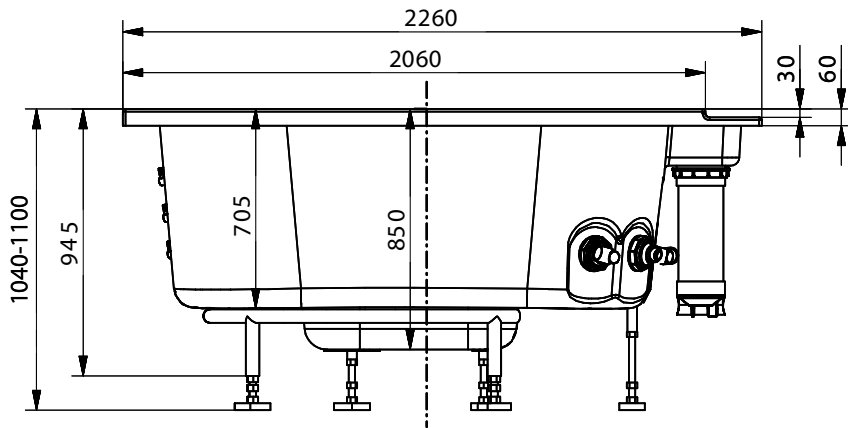

## 1.4 Roman 195 Inground Whirlpool

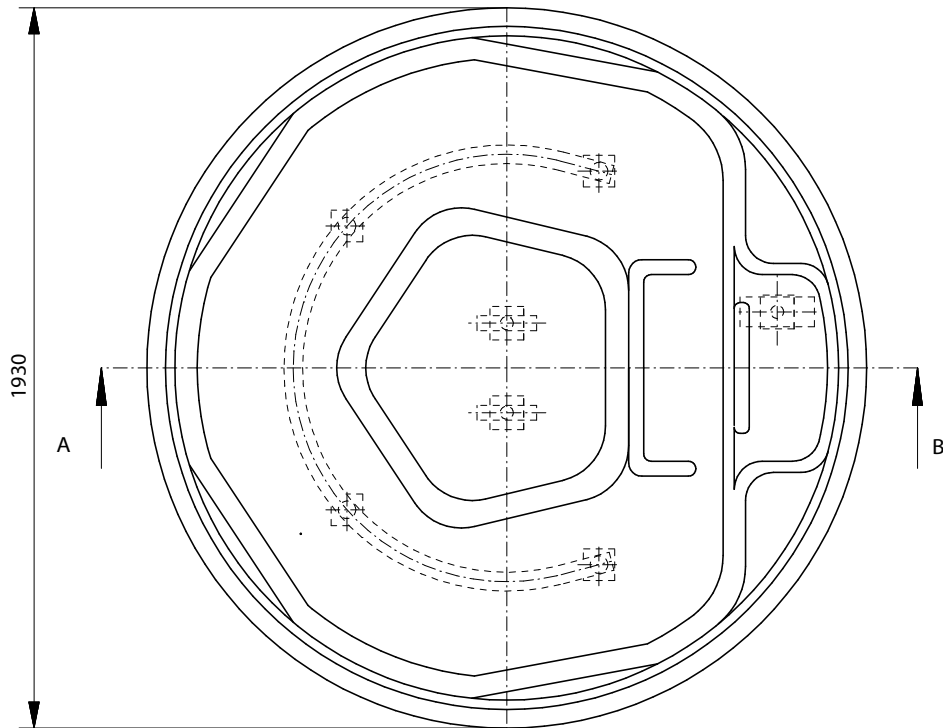
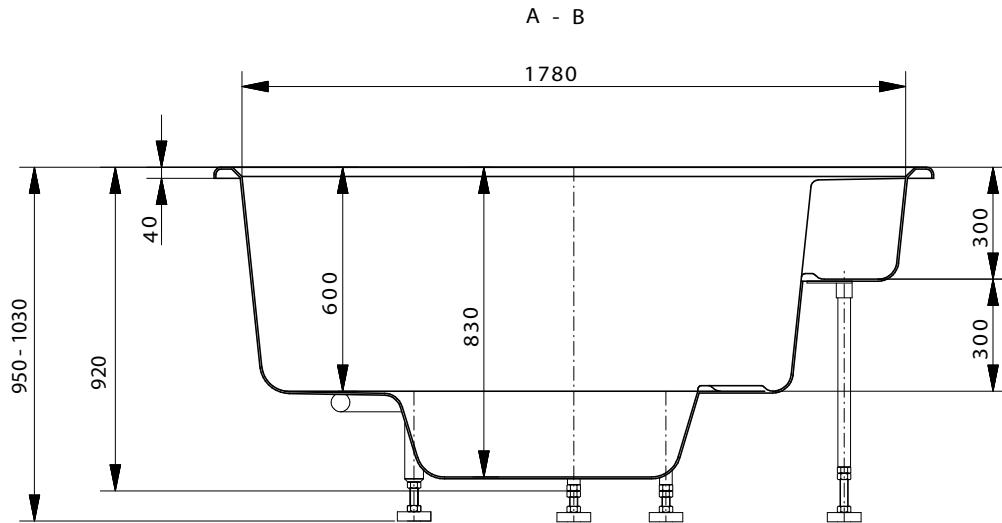

## 1.5 Roman 225 Inground Whirlpool

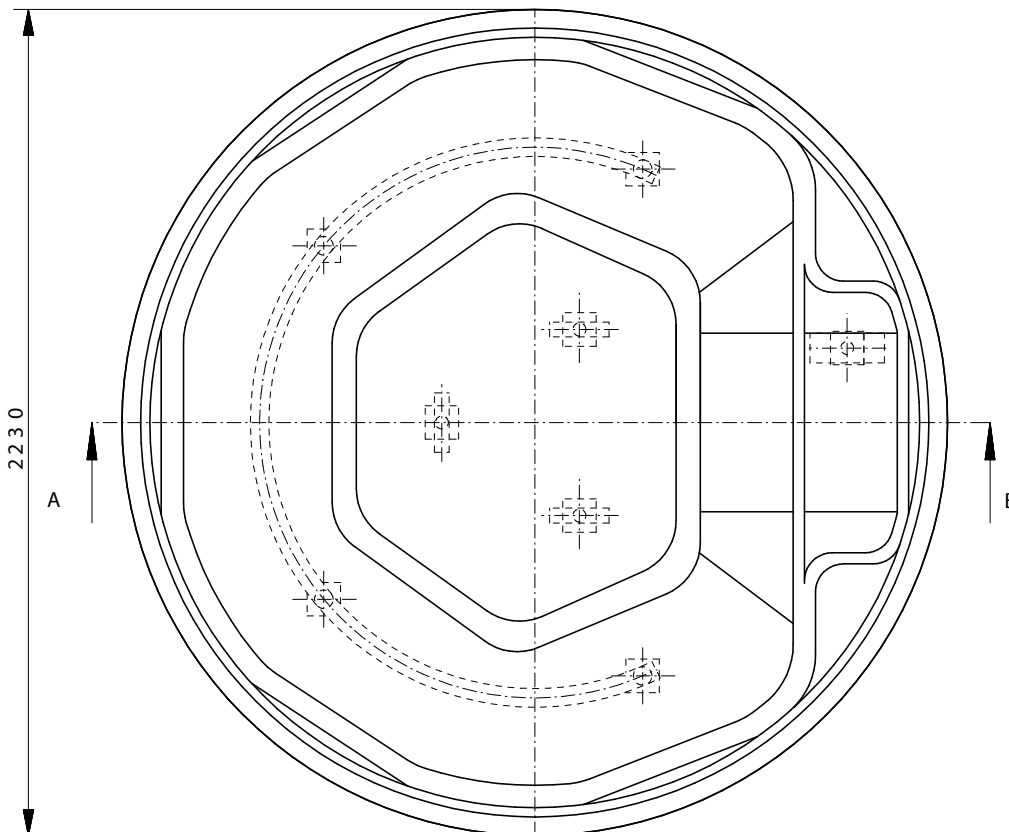
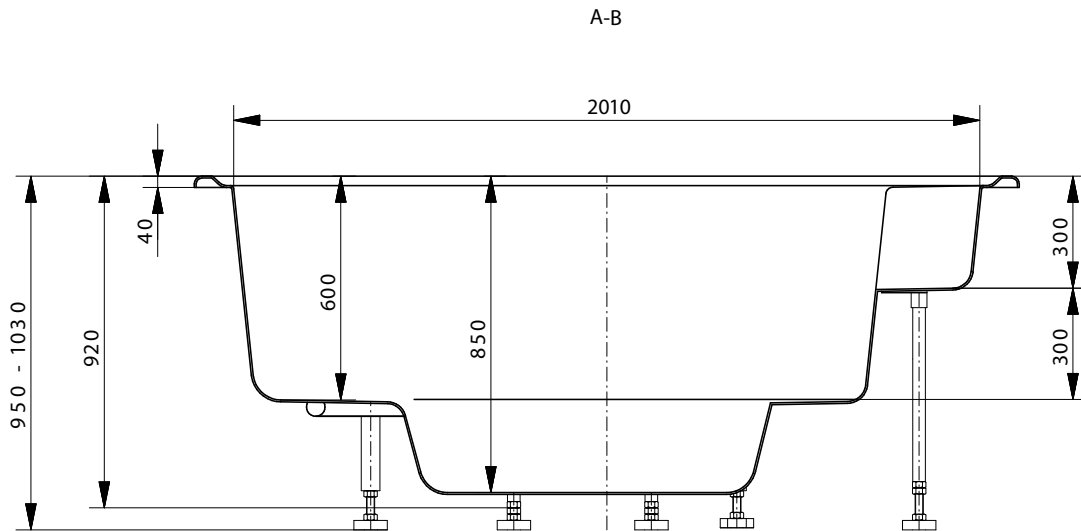

## 2.2 General Information / Requirements on site

### 2.1 Specific Use and Purpose

Built-in whirlpools with the appropriate equipment and accessories are warm water bubble pools, that are designed for private and family use and are installed in fitness centers, hotels and large bathing areas. Outdoor installation is possible provided special precautions are taken regarding winterizing.

Private whirlpools contain about 700 – 1500 liters of water and are therefore too large to be filled and emptied with warm water each time a person bathes in the whirlpool. These whirlpools are like a swimming pool and need to be equipped with a filtration and heating system that maintains the proper disinfection and temperature of the water at all times. The water needs to be treated and disinfected (see „Care and Maintenance“- pages 17 and 18). The water needs to be changed about every 2 months. At that time the pool should be cleaned manually. Only clean tap water from the public supply should be used to refill the pool. The water quality should be like drinking water. Private whirlpools emit humidity and sound. Therefore, a steam barrier, a humidifier and dehumidifier, and a whirlpool cover need to be installed, and, if necessary, special measures need to be taken to absorb the noise.

The maximum water temperature in the whirlpool can not be higher than 40° C. The chloride level can not be higher than 300 mg/l. If you want to install a private whirlpool in a situation that is different from the one described above and as described in the installation and service instructions, we ask you to please contact us. There are different solutions available, for instance when salt water is used. Inappropriate use voids the warranty.

### 2.2 Subsoil/Foundation

The foundation should be level and firm and have the same dimensions as the whirlpool (see data sheet). The entire base of the whirlpool must stand completely flat on the ground so that its weight is properly supported. There must be sufficient head room above the whirlpool for getting in and out with ease. If the pool is dropped in the ground, the prepared recess clearance in the base plate should be about 10 cm wider than the outside dimensions of the pool. The piping and insulation are located beneath the pool edge. The concrete base for the equipment pack needs to be at the same level as the pool, so that the pumps are always filled with water. The distance between the equipment and the pool should never be more than 5 meters.

### 2.3 Power supply

Total connected load: 2 x 16 A/230 V/50 Hz and a 30 m A ground fault interrupter (GFI). Strato 2.0 one supply line 16 Amp. and a 30 m A ground fault interrupter. The whirlpool must be connected to the main power supply using a cable with a cross-section of 3 x 2,5 mm<sup>2</sup>. The installation should be carried out by a qualified and licensed electrician and in compliance with local regulations.

#### Allocation of the supply lines:

Supply line 1 =	• Massage pump 1	1,0 kW
	• Massage pump 2	1,5 kW
	• Blower	0,5 kW
	• Filtration pump	0,33 kW
	• Heater 1	3 kW
	(locked against massage pumps)	

Supply line 2 =	• Heater	2 kW
-----------------	----------	------



- 2.4 Fresh water** Only water of drinking water quality from the mains should be used.
- 2.5 Waste water** The whirlpool should be emptied into the public sewage system (see diagram for the proper connection).
- 2.6 Delivery** The whirlpool is delivered on a pallet. The whirlpool should be transported to its destination completely packed, to avoid damage during transportation to the installation site. Immediately upon arrival the pool should be unpacked and inspected for any sign of damage.
- 2.7 Noise insulation** If the pool is installed next to bedrooms, for example, or any other rooms which according to DIN 4109 require special noise insulation, additional measures will have to be taken.

## 3. Installation description

### 3.1 Installation Diagram

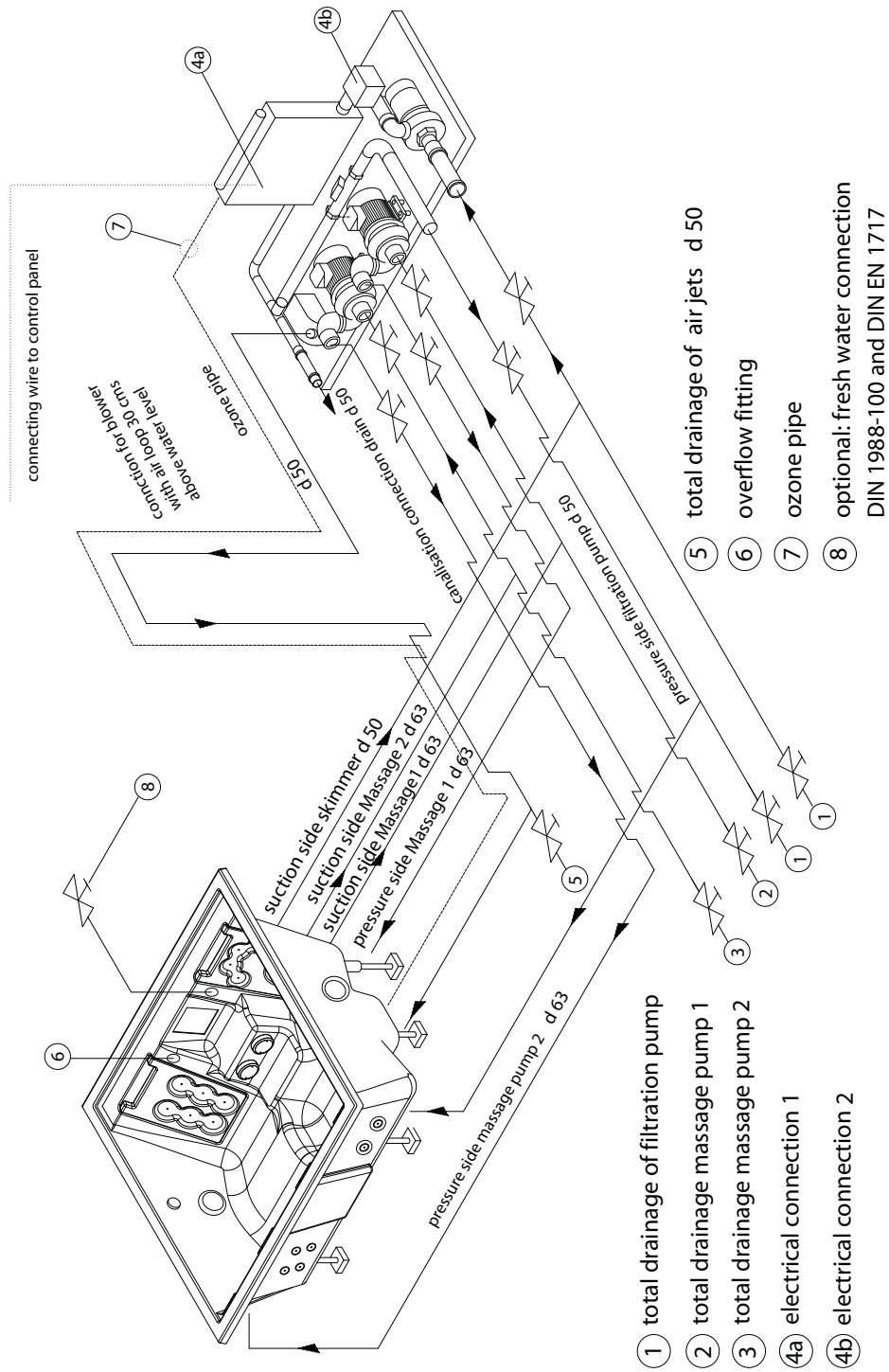

## 3.2 Connections to the pool

3.3 Description technical package ELS

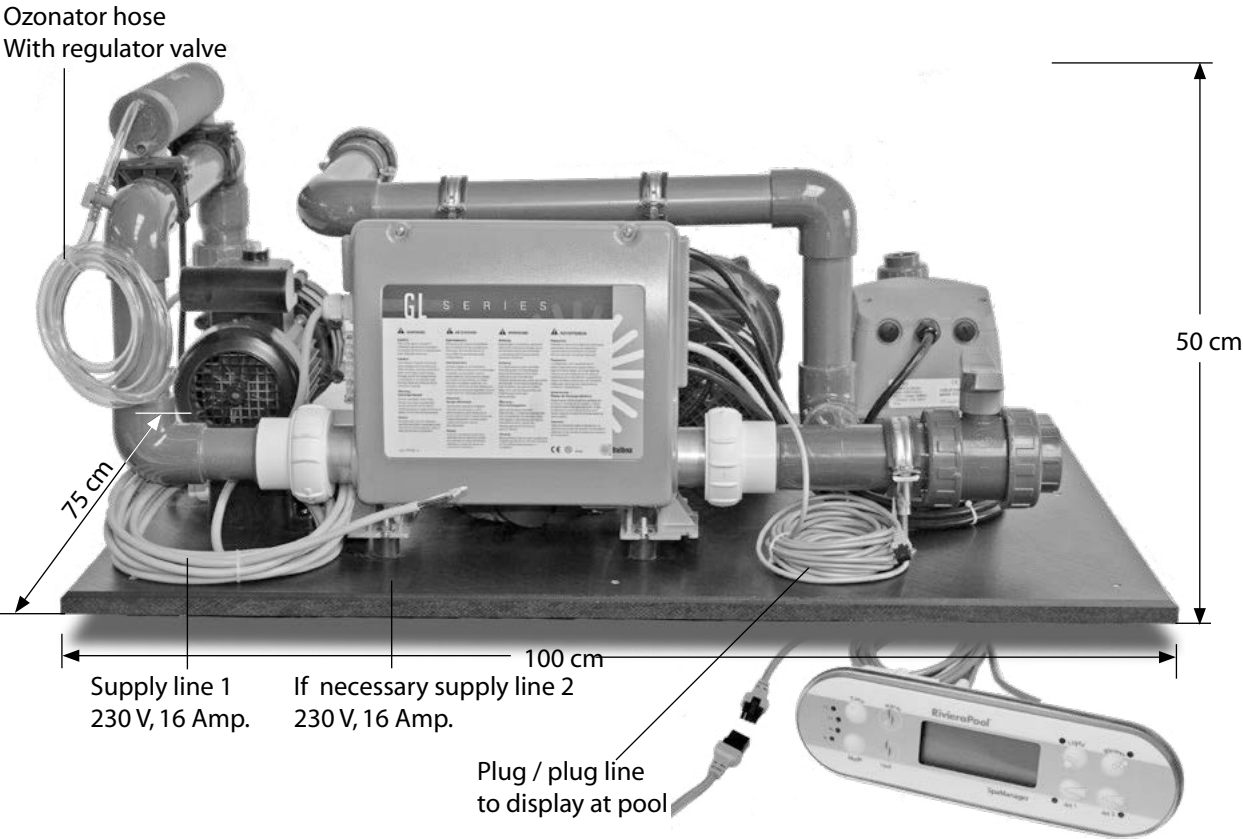
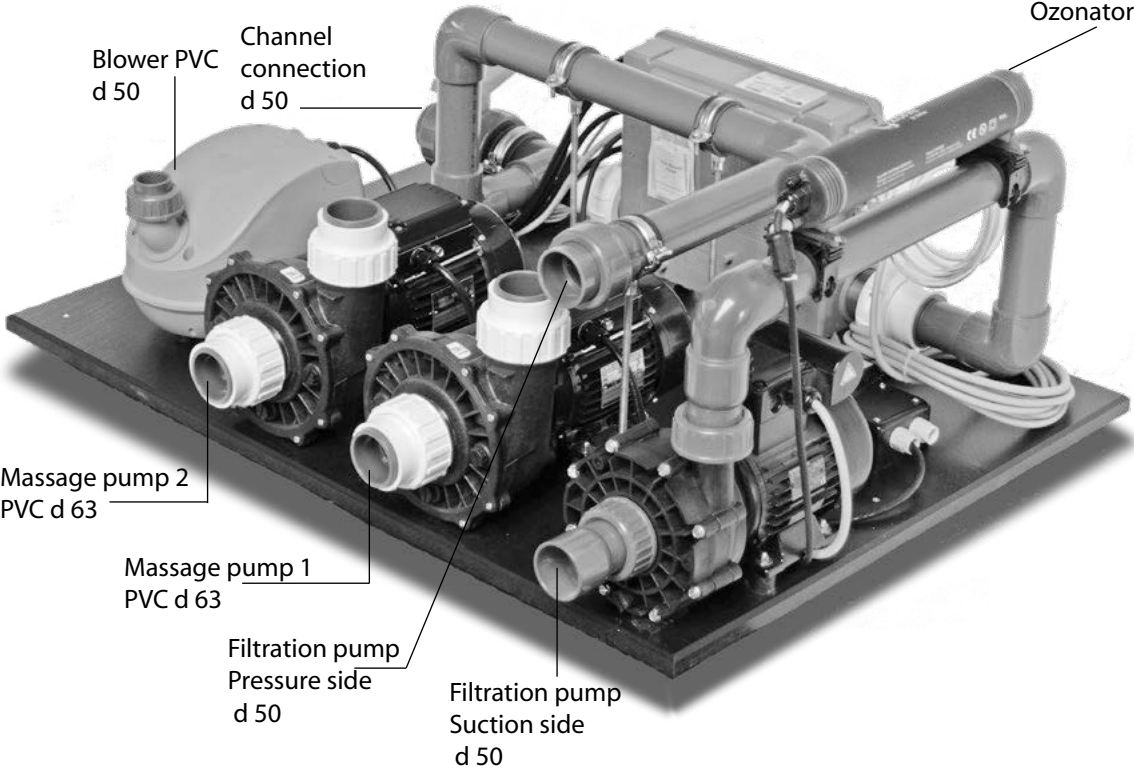

## 3.4 Description technical package PWW

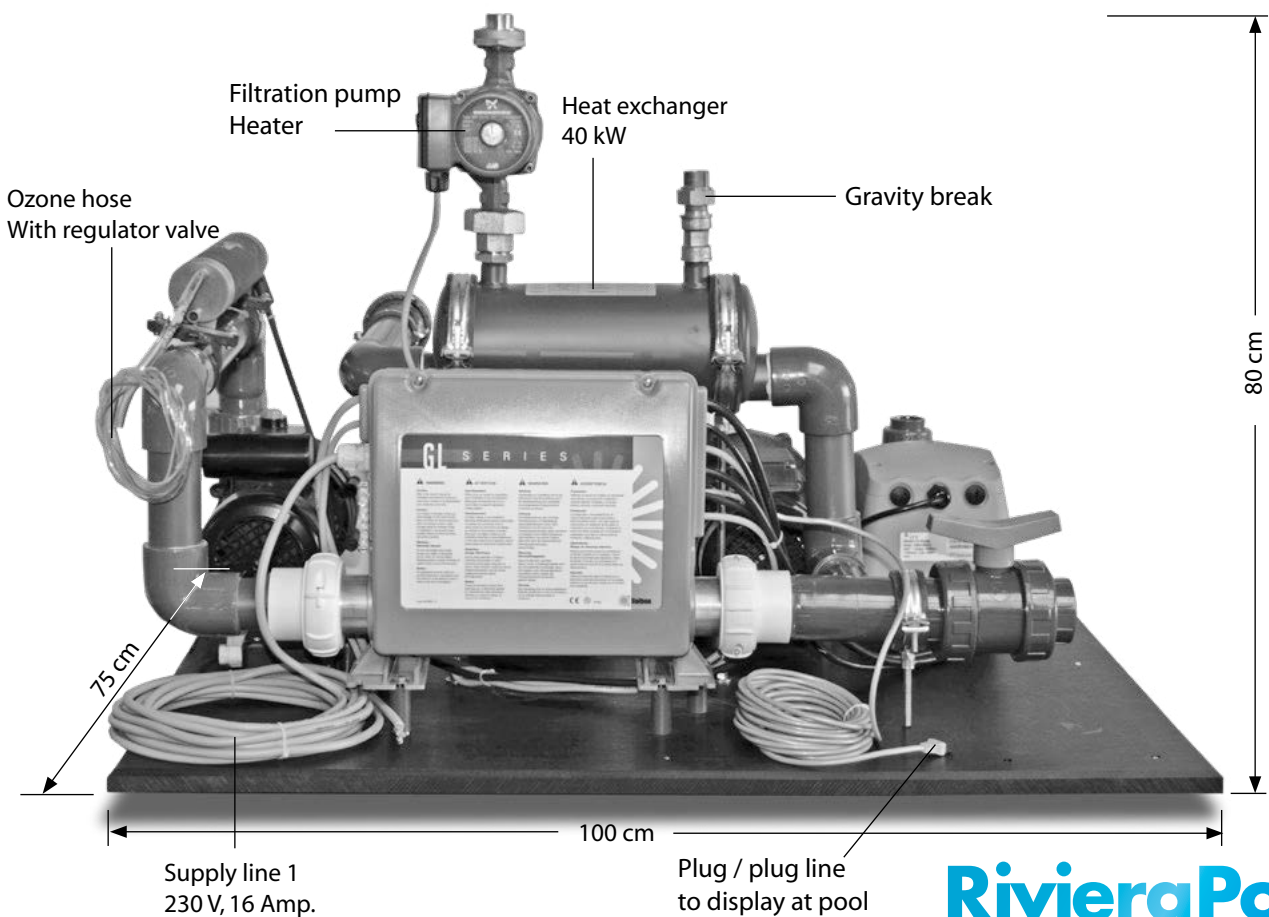
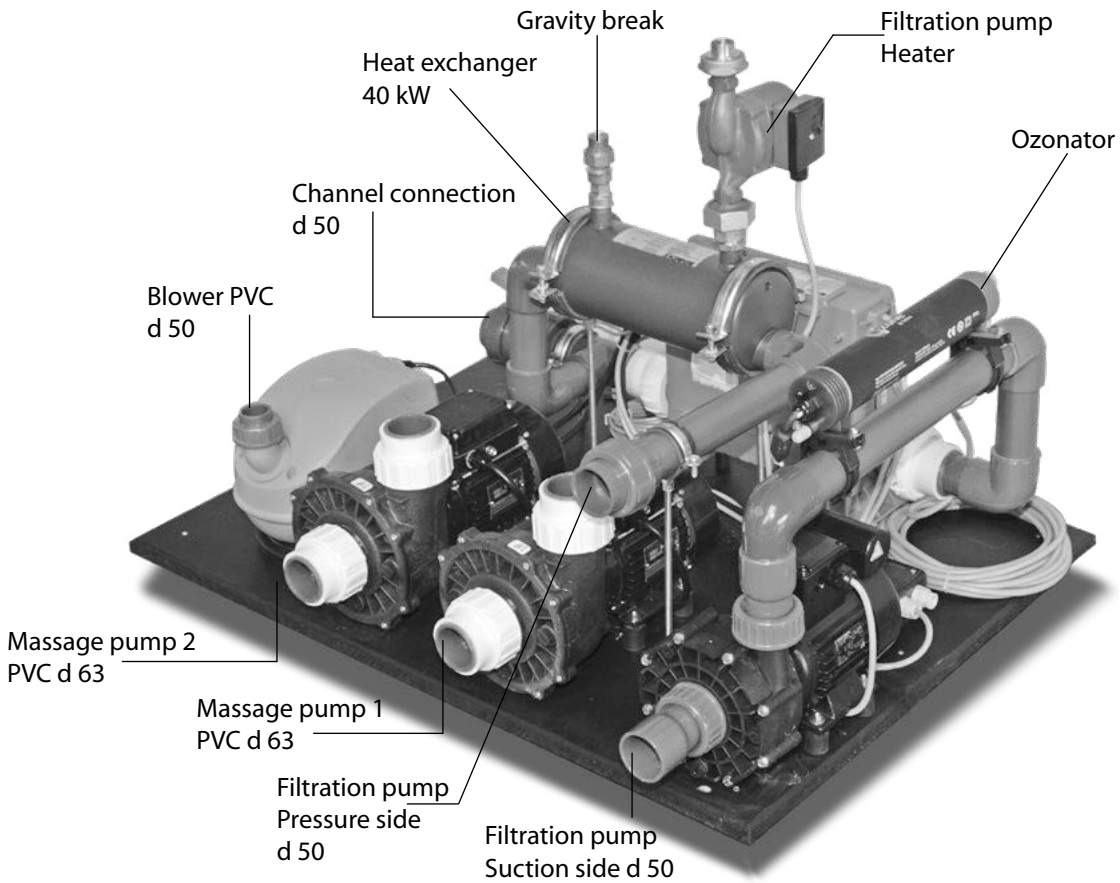

## 4. Noise reduction

### 4.1. Installing noise insulation precautions

Because of the way they are constructed, whirlpools produce a certain noise that is transmitted via material or air. In order to keep noise transmission to a minimum, we recommend installation according to the following instructions.

### 4.2 Installation without special noise insulation precautions

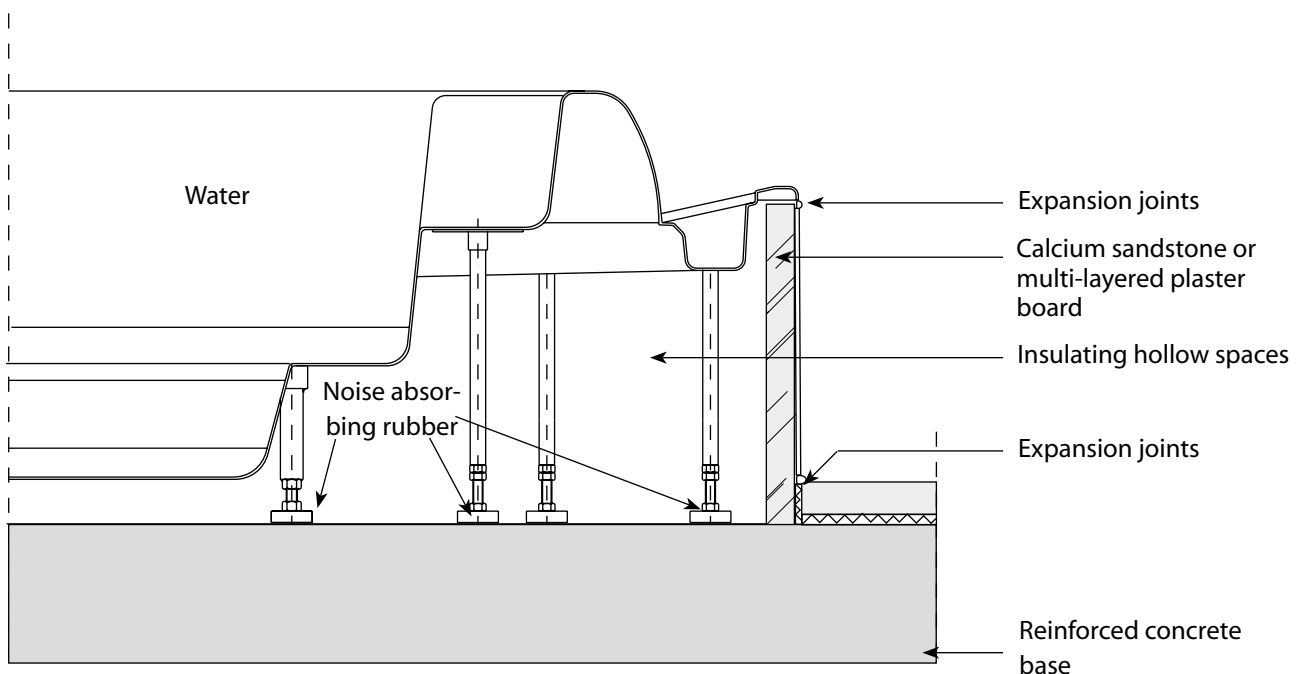

This recommendation is only sufficient if there are no rooms next to or below the installation room that require noise insulation according to VDI 4100 / DIN 4109 regulation.

- The edge of the bath tub should not lay directly on the tub wall. Opportunities for noise transmission should be avoided.
- Pipes that are installed through a wall should never be in direct contact with this wall (use noise absorbing sheathing).
- Install compensators in the pipe lines between the whirlpool and the aggregates.
- Assembly foam is acoustically not suitable (noise transmission).
- The hollow room under the tub should be protected with material that prevents noise from reverberating through the air (should be at least 200mm thick).
- Install noise absorbing bearings underneath the feet of the tub.

## 4. Noise reduction

### 4.3 Installation with special noise precautions.

More stringent noise absorbing requirements occur when living areas are situated below the whirlpool. The sound level in these rooms can not exceed the 35 dbA limit prescribed by DIN 4109 (25 dbA in industrial spaces). This noise level depends basically on the construction of the building and the installation, and the way the installation has been assembled. Therefore, we recommend individual, custom-made sound reducing planning on the basis of the diagram below.

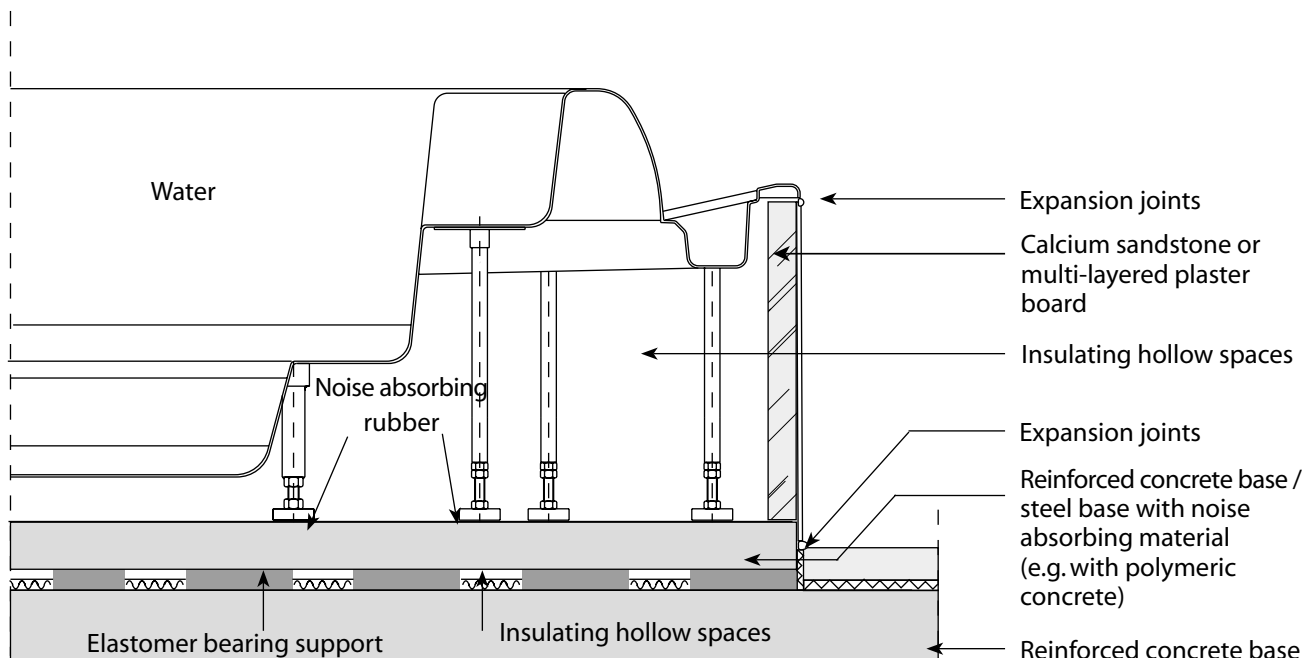

This recommendation is only sufficient if there are no rooms next to or below the installation room that require noise insulation according to VDI 4100 / DIN 4109 regulation.

- The edge of the bath tub should not lay directly on the tub wall. Opportunities for noise transmission should be avoided.
- Pipes that are installed through a wall should never be in direct contact with this wall (use noise absorbing sheathing).
- Install compensators in the pipe lines between the whirlpool and the aggregates.
- Assembly foam is acoustically not suitable (noise transmission).
- The hollow room under the tub should be protected with material that prevents noise from reverberating through the air (should be at least 300mm thick).
- Noise absorbing bearings underneath the feet of the tub and underneath the reinforced concrete base / steel base; agreed-on frequency  $f_0 = 10-12$  Hz.
- Also required: elastic buffering of the reinforced concrete base (horizontal movement  $< 1$  mm). Caution: Connections!

## 5. Installation example

### Installation example Octagon 195

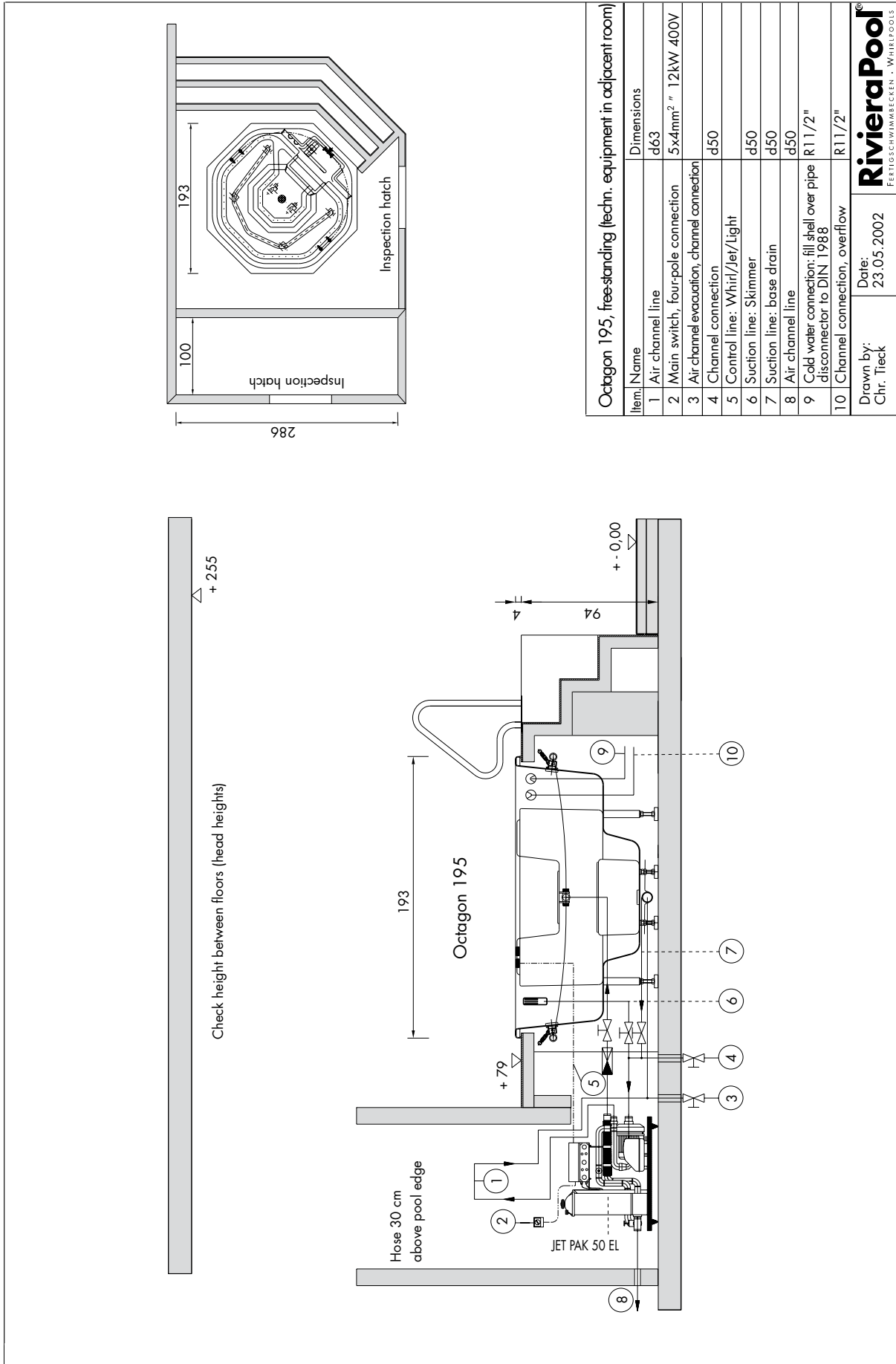

Octagon 195, free-standing (techn. equipment in adjacent room)

Item	Name	Dimensions
1	Air channel line	d63
2	Main switch, four-pole connection	5x4mm <sup>2</sup> " 12kW 400V
3	Air channel evacuation, channel connection	d50
4	Channel connection	d50
5	Control line: Whirl/Jet/Light	d50
6	Suction line: Skimmer	d50
7	Suction line: base drain	d50
8	Air channel line	d50
9	Cold water connection: fill shell over pipe disconnect to DIN 11988	R1 1/2"
10	Channel connection, overflow	R11/2"

Drawn by: Chr. Tieck	Date: 23.05.2002
<b>RivieraPool</b> <small>FERTIGSCHWIMMBECKEN - WHIRLPOLS</small>	



## Installation example a Strato 2.0

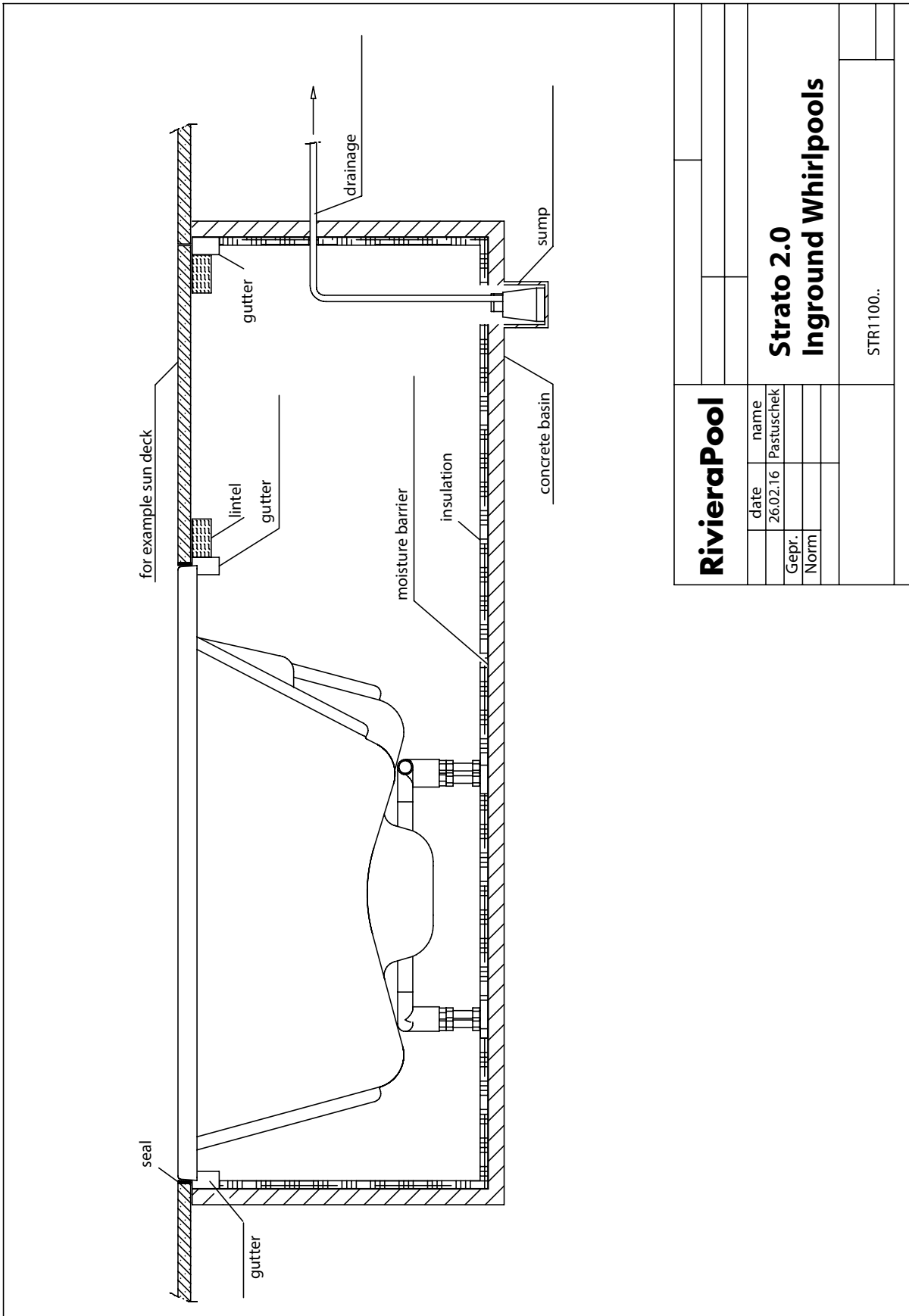

<b>RivieraPool</b>		date	name
		26.02.16	Pastuschek
Gepr.			
Norm			
		<b>Strato 2.0</b>	
		<b>Inground Whirlpools</b>	
		STR1100..	

## 6. Installation description

### 6.1 Switching the power supply on and off for the first time



Fill the spa to its correct operating level. Be sure to open all valves and jets in the plumbing system before filling to allow as much air as possible to escape from the plumbing and the control system during the filling process. After turning the power on at the main power panel, the top-side panel will display a splash screen or startup screen.

#### „Priming“-Modus-M019\*

After the initial start-up sequence, the control will enter Priming Mode and display a Priming Mode screen. Only pump icons appear on the priming mode screen. During the priming mode, the heater is disabled to allow the priming process to be completed without the possibility of energizing the heater under low-flow or no-flow conditions. Nothing comes on automatically, but the pump(s) can be energized by selecting the “Jet” buttons. If the spa has a Circ Pump, it can be turned on and off by pressing the “Circ Pump” button during Priming Mode.

#### Priming the Pumps

As soon as the Priming Mode screen appears on the panel, select the “Jets 1” button once to start Pump 1 in low-speed and then again to switch to high-speed. Also, select the other pumps, to turn them on. The pumps should be running in high-speed to facilitate priming. If the pumps have not primed after 2 minutes, and water is not flowing from the jets in the spa, do not allow the pumps to continue to run. Turn off the pumps and repeat the process.

Note: Turning the power off and back on again will initiate a new pump priming session. Sometimes momentarily turning the pump off and on will help it to prime. Do not do this more than 5 times. If the pump(s) will not prime, shut off the power to the spa and call for service.

Important: A pump should not be allowed to run without priming for more than 2 minutes. Under NO circumstances should a pump be allowed to run without priming beyond the end of the 4-5 minute priming mode. Doing so may cause damage to the pump and cause the system to energize the heater and go into an overheat condition.

#### Exiting Priming mode

The system will automatically enter the normal heating and filtering at the end of the priming mode, which lasts 4-5 minutes.

You can manually exit Priming Mode by pressing the “Exit” button on the Priming Mode Screen. Note that if you do not manually exit the priming mode as described above, the priming mode will be automatically terminated after 4-5 minutes. Be sure that the pump(s) have been primed by this time.

Once the system has exited Priming Mode, the top-side panel will display the Main Screen, but the display will not show the temperature yet, as shown below. This is because the system requires approximately 1 minute of water flowing through the heater to determine the water temperature and display it.

— — — — °F      — — — — °C

## 6.2 Operation of the massage jets

### 6.2.1 Opening and closing the nozzles

The jets faceplate can be rotated clockwise to close them off. Turn the anti-clockwise to open the water flow. The nozzles can be adjusted to a Center position to reduce pressure from that jet. This may, however, automatically adjust to open by the water pressure. If one or more jets is closed then the pressure in the remaining open jets is automatically amplified.

Note: If a nozzle has too little power, this is usually because the jet is not open properly.

**Note:** If a nozzle has too little power, this is usually because the jet is not open properly.



### 6.2.2 Operation of Jet controls

The Jet control knob allows the water power of the massage pump to be distributed between two opposing seats. When centrally adjusted, the power of the massage pump is evenly distributed to both seats.

### 6.2.3 Intake

In the massage jets will automatically draw air into the jet stream when the pumps are operated. This Air intake is below the spa shell and incorporated in the cladding. A schematic of this air flow is not provided.

## 6.4 Operating the digital display

### 6.3.1 Operating the digital display SPA status

Important information about spa operation can be seen on the Main Screen. Most features, including Set Temperature adjustment, can be accessed from this screen.

The actual water temperature and Set Temperature can be seen, and the Set Temperature can be adjusted (see page 22).

Time-of-Day, Ozone and Filter status is available, along with other messages and alerts.

The selected Temperature Range is indicated in the upper right corner. The Jets Icon in the center will spin if any pump is running and changes color when the heater is on.

A Lock icon is visible if the panel or settings are locked.

The Menu choices on the right can be selected and the screen will change to show more detailed controls or programming functions.

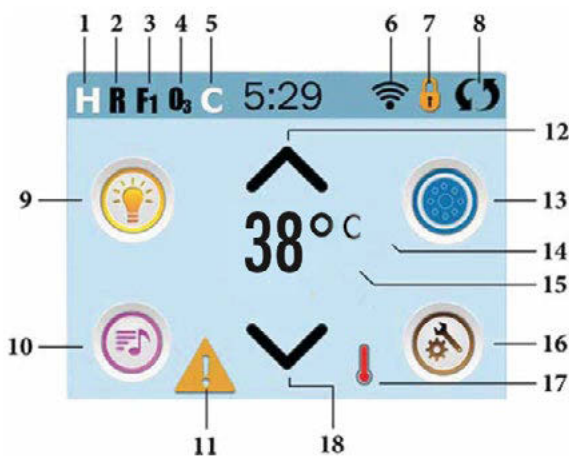

#### ICON Specifications

1. H = High Temperature Range
2. R = Ready Mode
3. F1 = Filter Cycle 1 Running
4. O3 = Ozone Running
5. C = Cleanup Cycle
6. Wi-Fi Signal Indicator
7. Lock Indicator
8. Invert Screen
9. Light Icon = Turns On/Off
10. Music Icon = Press To Enter Music Screen
11. Message Waiting Indicator
12. Set Temperature Up
13. Spa Equipment Control Icon
14. Temperature Scale (F/C)
15. Current Water Temperature
16. Settings Icon
17. Heat Indicator
18. Set Temperature Down

**Note:** After 30 minutes the display will automatically go into sleep mode, which turns the display off. This is normal operation. Touch anywhere on the screen to wake the panel up.

## Navigation

Navigating the entire menu structure is done by touching the screen. When a text item is shown in white on the main screen, it is selectable. The menu selections on the right side of the screen can be selected. Select one of these to enter a different screen with additional controls.

Most menu screens time out and revert to the main screen after 30 seconds of no activity. The only item that can be changed on the left side of the Main Screen is the Set Temperature. Touch either the set temperature line or the water temperature to go to the Set Temperature screen. See next page.

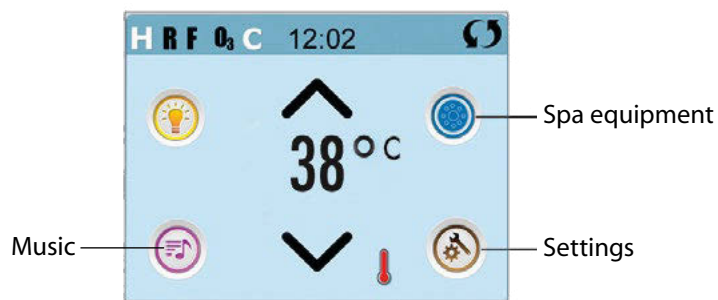

## Messages

At the bottom of the screen, messages may appear at various times. Some of these messages must be dismissed by the user (see pages 22-26).



A warning message is waiting

## 6.3.2 Setting the temperature

### Set Temperature

Press Inc or Dec to modify the Set Temperature. The Set Temperature changes immediately. Press Back to return to the Main Screen.

If you need to switch between high range and low range you need to go to the Settings Screen.

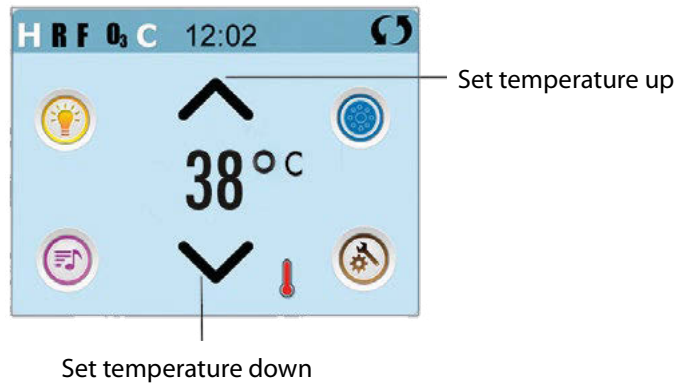

### Press-and-Hold

If the Up or Down button is pressed and held, the temperature will continue to change until the button is released, or the Temperature Range limits are reached.

## 6.3.3 The Spa screen (user functions) All Equipment Access



The Spa Screen shows all available equipment to control, as well as other features, like Invert. The display shows icons that are related to the equipment installed on a particular spa model, so this screen may change depending on the installation. The icon buttons are used to select and control individual devices. Some devices, like pumps, may have more than one ON state, so the icon will change to reflect the state that the equipment is in. Below are some examples of 2-speed Pump indicators.



If the Spa has a Circ Pump, a Circ Pump Icon will appear to indicate its activity, but outside of Priming Mode, the Circ Pump cannot be controlled directly.

**NOTE:** The icon for the pump that is associated with the heater (Circ or P1 Low) will have a red glow in the center when the heater is running.

## 6.3.4 Command Buttons

### Exiting Screens

When you see both of these buttons, whether they are labeled or not, they always mean Save and Cancel.

They appear on most editing screens once you have changed the value on that screen.

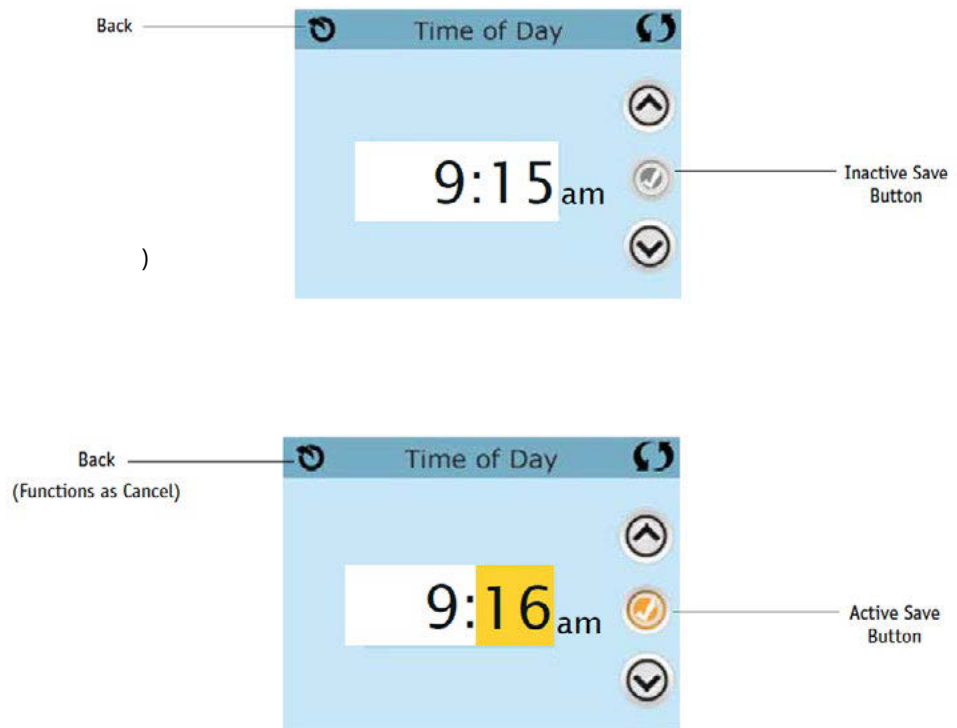

When you see only this button, whether it is labeled or not, it means Back or Exit. It appears on editing screens before you have changed any value, as well as on all other screens.

### Values Increment/Decrement

If an Up or Down button is shown and pressed when on an editing page, and a value has been selected (highlighted), the value can be incremented by pressing the up arrow or decremented by pressing the down arrow.

## Invert



## Page Up/Down

If an Up or Down button is shown and pressed when in a Menu List, the list can be scrolled a page at a time.

The scroll bar on the right side of the screen indicates the relative position of the page.

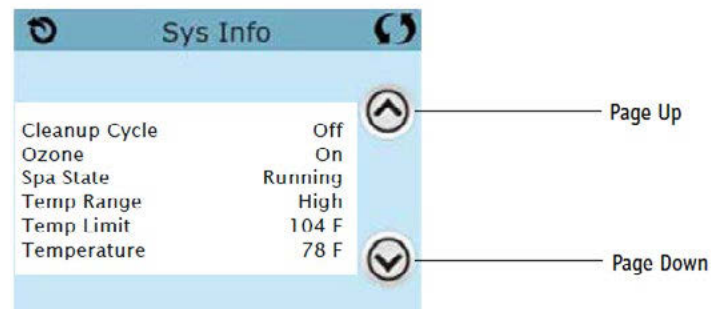

## Values Increment/Decrement

If an Up or Down button is shown and pressed when on an editing page, and a value has been selected (highlighted), the value can be incremented by pressing the up arrow or decremented by pressing the down arrow.

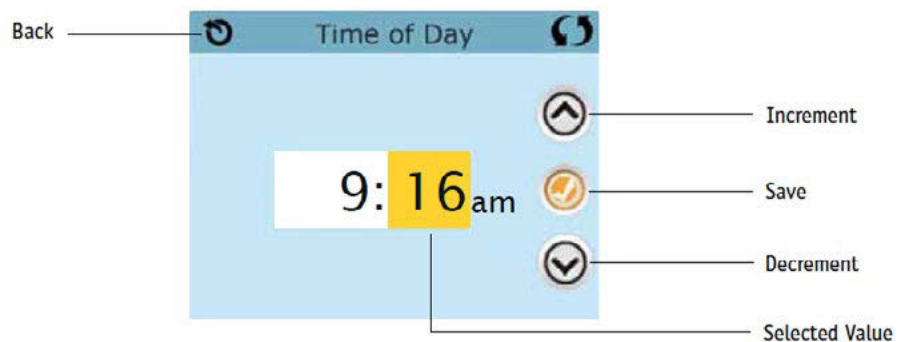



## 6.3.5 Screenshot: Settings

### Programming, Etc.

The Settings Screen is where all programming and other spa behaviors are controlled. This screen has several features that can be acted on directly. These features may include Temp Range, Heat Mode, Hold, and Invert Panel. When one of these items is selected, it will toggle between two settings.

All other menu items (with an arrow pointing to the right) go to another level in the menu.



## 6.3.6 Settings for the temperature ranges

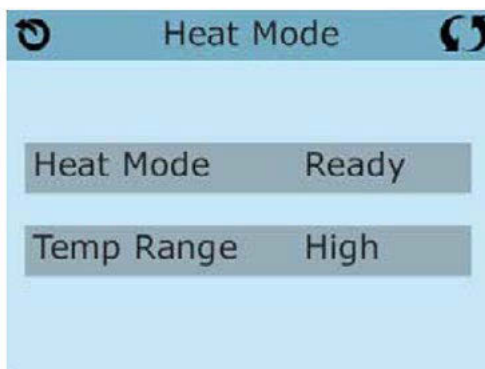

### Dual Temperature Ranges (High vs. Low)

This system incorporates two temperature range settings with independent set temperatures. The specific range can be selected on the Settings screen and is visible on the Main Screen in the upper right corner of the display.

These ranges can be used for various reasons, with a common use being a "ready to use" setting vs. a "vacation" setting.

Each range maintains its own set temperature as programmed by the user. This way, when a range is chosen, the spa will heat to the set temperature associated with that range.

High Range can be set between 80°F and 104°F.

Low Range can be set between 50°F and 99°F.

More specific Temp Ranges may be determined by the Manufacturer.

Freeze Protection is active in either range.

## **Heat Mode – Ready vs. Rest**

In order for the spa to heat, a pump needs to circulate water through the heater. The pump that performs this function is known as the "heater pump."

The heater pump can be either a 2-speed pump (Pump 1) or a circulation pump. If the heater pump is a 2-Speed Pump 1, Ready Mode will circulate water every 1/2 hour, using Pump 1 Low, in order to maintain a constant water temperature, heat as needed, and refresh the temperature display. This is known as "polling."

Rest Mode will only allow heating during programmed filter cycles. Since polling does not occur, the temperature display may not show a current temperature until the heater pump has been running for a minute or two.

When the heater pump has come on automatically (for example for heating) you can switch between low speed and high speed but you cannot turn the heater pump off.

Circulation Mode (See Page 11, under Pumps, for other circulation modes). If the spa is configured for 24HR circulation, the heater pump generally runs continuously. Since the heater pump is always running, the spa will maintain set temperature and heat as needed in Ready Mode, without polling.

In Rest Mode, the spa will only heat to set temperature during programmed filter times, even though the water is being filtered constantly when in 24HR circulation mode.

## **Ready-in-Rest Mode**

Ready in Rest Mode appears in the display if the spa is in Rest Mode and the Jets 1 Button is pressed. When the heater pump has come on automatically (for example for heating) you can switch between low speed and high speed but you cannot turn the heater pump off. After 1 hour, the System will revert to Rest Mode. This mode can also be reset by entering the Settings Menu and selecting the Heat Mode line.

## Fill it up!

Fill the spa to its correct operating level. Be sure to open all valves and jets in the plumbing system before filling to allow as much air as possible to escape from the plumbing and the control system during the filling process.

After turning the power on at the main power panel, the top-side panel will display a splash screen or startup screen.



## „Priming“ mode-M019\*

After the initial start-up sequence, the control will enter Priming Mode and display a Priming Mode screen. Only pump icons appear on the priming mode screen. During the priming mode, the heater is disabled to allow the priming process to be completed without the possibility of energizing the heater under low-flow or no-flow conditions. Nothing comes on automatically, but the pump(s) can be energized by selecting the “Jet” buttons. If the spa has a Circ Pump, it can be turned on and off by pressing the “Circ Pump” button during Priming Mode.

## Priming the Pumps

As soon as the Priming Mode screen appears on the panel, select the “Jets 1” button once to start Pump 1 in low-speed and then again to switch to high-speed. Also, select the other pumps, to turn them on. The pumps should be running in high-speed to facilitate priming. If the pumps have not primed after 2 minutes, and water is not flowing from the jets in the spa, do not allow the pumps to continue to run. Turn off the pumps and repeat the process. Note: Turning the power off and back on again will initiate a new pump priming session. Sometimes momentarily turning the pump off and on will help it to prime. Do not do this more than 5 times. If the pump(s) will not prime, shut off the power to the spa and call for service.

Important: A pump should not be allowed to run without priming for more than 2 minutes. Under NO circumstances should

a pump be allowed to run without priming beyond the end of the 4-5 minute priming mode. Doing so may cause damage to

the pump and cause the system to energize the heater and go into an overheat condition.

## Exiting Priming mode

The system will automatically enter the normal heating and filtering at the end of the priming mode, which lasts 4-5 minutes.

You can manually exit Priming Mode by pressing the “Exit” button on the Priming Mode Screen. Note that if you do not manually exit the priming mode as described above, the priming mode will be automatically terminated after 4-5 minutes.

Be sure that the pump(s) have been primed by this time. Once the system has exited Priming Mode, the top-side panel will display the Main Screen, but the display will not show the temperature yet, as shown below. This is because the system requires approximately 1 minute of water flowing through the heater to determine the water temperature and display it.

— — — °F      — — — °C

## 6.3.8 Filtration

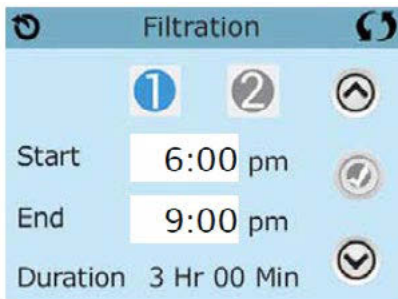
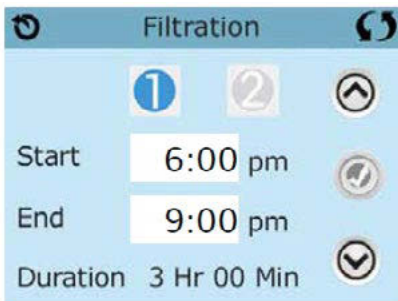

### Main Filtration

Using the same adjustment as Setting the Time, Filter Cycles are set using a start time and a duration. Each setting can be adjusted in 15-minute increments. The panel calculates the end time and displays it automatically.

### Filter Cycle 2 - Optional Filtration

Filter Cycle 2 is OFF by default. This displays as "No". When Filter Cycle 2 is ON it displays as "Yes". Press "Yes" or "No" to toggle Filter Cycle 2 ON or OFF. When Filter Cycle 2 is ON, it can be adjusted in the same manner as.

### Filter Cycle 1.

It is possible to overlap Filter Cycle 1 and Filter Cycle 2, which will shorten overall filtration by the overlap amount.

### Circulation Pump Modes

Some spas may be manufactured with Circ Pump settings that allow programming filtration cycle duration. Some circ Modes are pre-programmed to operate 24 hours a day and are not programmable. Refer to the spa manufacturer's documentation for any Circ Mode details.

### Purge Cycles

In order to maintain sanitary conditions, as well as protect against freezing, secondary water devices will purge water from their respective plumbing by running briefly at the beginning of each filter cycle. (Some systems will run a certain number

of purge cycles per day, independent of the number of filter cycles per day. In this case, the purge cycles may not coincide with the start of the filter cycle.). If the Filter Cycle 1 duration is set for 24 hours, enabling Filter Cycle 2 will initiate a purge when Filter Cycle 2 is programmed to begin.

### The Meaning of Filter Cycles

1. The heating pump always runs during the filter cycle\*
2. In Rest Mode, heating only occurs during the filter cycle
3. Purges happen at the start of each filter cycle

\* For example, if your spa is set up for 24/hour circulation except for shutting off when the water temperature is 3°F/1.3°C above the set temperature, that shutoff does not occur during filter cycles.

### Filtration and Ozone

On non-circ systems, Pump 1 low and the ozone generator will run during filtration. On circ systems, the ozone will generally run with the circ pump, but can be limited to filtration cycles. (On some circs systems, Pump 1 low will run along with the circ Pump during filtration.) The system is factory-programmed with one filter cycle that will run in the evening (assuming the time-of-day is properly set) when energy rates are often lower. The filter time and duration are programmable. (See page 13) A second filter cycle can be enabled as needed.

At the start of each filter cycle, the water devices like blower, mister device (if these exist) and other pumps will run briefly to purge the plumbing to maintain good water quality.

## 6.3.9 Frost protection

If the temperature sensors within the heater detect a low enough temperature, then the water devices automatically activate to provide freeze protection. The water devices will run either continuously or periodically depending on

conditions. In colder climates, an optional freeze sensor may be added to protect against freeze conditions that may not be sensed by the standard sensors. Auxiliary freeze sensor protection acts similarly except with the temperature thresholds determined by the switch. See your dealer for details.

### Clean-up Cycle (optional)

When a pump or blower is turned on by a button press, a clean-up cycle begins 30 minutes after the pump or blower is turned off or times out. The pump and the ozone generator will run for 30 minutes or more, depending on the system. On some systems, you can change this setting. (See the Preferences section on page 18)

### Description of filter cycles

1. The heating pump is always running during the filter cycle. \*
2. In idle mode the spas is heated only during the filter cycle.
3. cleaning at the beginning of each filter cycle.

\* If your SPA is for example in the 24-hour circulation mode and the water temperature is 3° F / 1.3° C below the set temperature, then the heating will not turn off during the filter cycle.

### 6.3.10 Auxiliary control panel (s)

#### Specific Buttons for Specific Devices.:

If the spa has an Auxiliary Panel(s) installed, pressing buttons on that panel will activate the device indicated for that button.

These dedicated buttons will operate just like the Spa Screen buttons (see page 5) and the equipment will behave in the same manner with each button press.

### 6.3.11 Locking the operating keys

**Restricting Operation:** The control can be restricted to prevent unwanted use or temperature adjustments. Locking the Panel prevents the controller from being used, but all automatic functions are still active.

Locking the Settings allows Jets and other features to be used, but the Set Temperature and other programmed settings cannot be adjusted. Settings Lock allows access to a reduced selection of menu items. These include Filter Cycles, Invert, Information and Fault Log. They can be seen, but not changed or edited.

1. Please touch and hold the settings/screen for 2 seconds.
2. To finish please hold the top bar of the screen for 2 seconds until the operating screen changes.



## Unlocking

To unlock either Settings or Panel first select Settings (if it says "On") or Panel (if it says "On"), then press in the middle of the screen for at least 5 seconds.

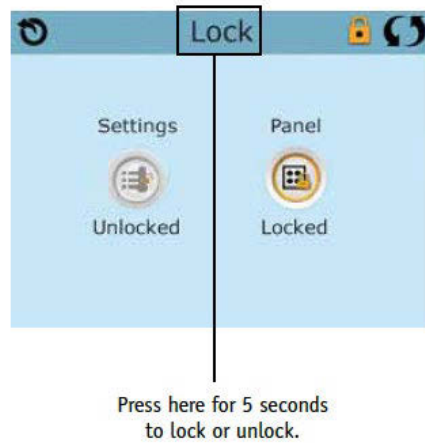

## 6.3.12 The Fault Log

The Fault Log is a record of the last 24 faults that can be reviewed by a service tech.

Use the Up and Down buttons to view each of the Faults. When Priming Mode shows in the Fault Log, it is not a fault.

Rather, it is used to keep track of spa restarts.

## 6.3.13 Information

### System information

The System Information Menu displays various settings and identification of the particular system. As each item in the menu is selected, the detail for that item is displayed at the bottom of the screen.



#### Software 10 (SSID)

Displays the software ID number for the System.

#### System-Model

Displays the Model Number of the System.

#### Current Setup

Displays the currently selected Configuration Setup Number.

#### Configuration Signature

Displays the checksum for the system configuration file.

#### Heater Voltage (Feature not used on CE rated systems.)

Displays the operating voltage configured for the heater.

#### Heater Wattage as Configured in Software (CE Systems Only.)

Displays a heater kilowatt rating as programmed into the control system software (1-3 or 3-6).

**Heater Type** Displays a heater type ID number.

#### Dip Switch Settings

Displays a number that represents the DIP switch positions of S1 on the main circuit board.

#### Panel Version

Displays a number of the software in the topside control panel.

## 6.3.14 The cleaning cycle

When a pump or blower is turned on by a button press, a clean-up cycle begins 30 minutes after the pump or blower is turned off or times out. The pump and the ozone generator will run for 30 minutes or more, depending on the system. On some systems, you can change this setting. (See the Preferences section on page 33)

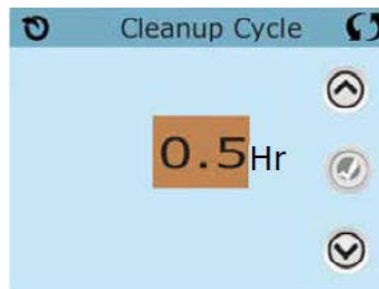

## 6.3.15 Preferences

### Preferences

The Preferences Menu allows the user to change certain parameters based on personal preference.

### Temp Display

Change the temperature between Fahrenheit and Celsius.

### Time Display

Change the clock between 12 hr and 24 hr display.

### Reminders

Turn the reminder messages (like "Clean Filter") On or Off.

### Cleanup

Cleanup Cycle Duration is not always enabled, so it may not appear. When it is available, set the length of time Pump 1 will run after each use. 0-4 hours are available.

### Dolphin Address (Applies to RF Dolphin only)

When set to 0, no addressing is used. Use this setting for a Dolphin II or Dolphin III which is factory set for no address by default. When set between 1 and 7, the number is the address. (See the Dolphin manual for details.)

### Colour

Selecting Colour will cycle through 5 background colors available in the control.

### Language

Change the language displayed on the panel under preferences.





## 6.3.16 General Information

Most messages and alerts will appear at the bottom of the normally used screens. Several alerts and messages may be displayed in a sequence.



### The water is too hot – M029\*

The system has detected a spa water temp of 110°F (43.3°C) or more, and spa functions are disabled. System will auto reset when the spa water temp is below 108°F (42.2°C). Check for extended pump operation or high ambient temp.

### Possible freezing condition

A potential freeze condition has been detected, or the Aux Freeze Switch has closed. All water devices are activated.

In some cases, pumps may turn on and off and the heater may operate during Freeze Protection.

This is an operational message, not an error indication.

— — °F — — °C

### Water temperature is unknown

After the pump has been running for 1 minute, the temperature will be displayed.

### The water level is too low

This message can only appear on a system that uses a water level sensor. It appears whenever the water level get too low (or the water level sensor is disconnected), and automatically disappears when the water level is adequate. Pumps and the heater turn OFF when this message appears.

## 6.3.17 Error messages for heating

### **The water flow is low – M016\*\***

There may not be enough water flow through the heater to carry the heat away from the heating element. Heater start up will begin again after about 1 min. See “Flow Related Checks” below.

### **The water flow has failed\* – M017\*\***

There is not enough water flow through the heater to carry the heat away from the heating element and the heater has been disabled. See “Flow Related Checks” below. After the problem has been resolved, reset the message\*.

### **The heater may be dry\* – M028\*\***

Possible dry heater, or not enough water in the heater to start it. The spa is shut down for 15 min. Reset this message\* to reset the heater start-up. See “Flow Related Checks” below.

### **The heater is dry\* – M027\*\***

There is not enough water in the heater to start it. The spa is shut down. After the problem has been resolved, you must reset the message\* to restart heater start up. See “Flow Related Checks” below.

### **The heater is too hot\* – M030\*\***

One of the water temp sensors has detected 118°F (47.8°C) in the heater and the spa is shut down. You must reset the message\* when water is below 108°F (42.2°C). See “Flow Related Checks” below.

### **Flow-related checks**

Check for low water level, suction flow restrictions, closed valves, trapped air, too many closed jets and pump prime.

On some systems, even when spa is shut down by an error condition, some equipment may occasionally turn on to continue monitoring temperature or if freeze protection is needed.

*\* Some messages can be reset from the panel. Messages that can be reset will appear with a “right arrow” at the end of the message.*

*Press the message text to reset the message.*

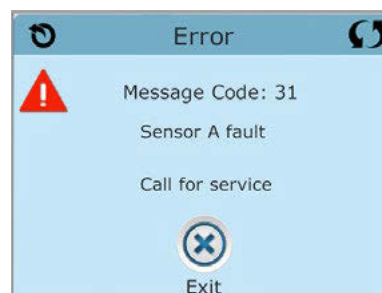

## 6.3.18 Error messages for sensors **Sensors are out of sync – M015\*\***

The temperature sensors MAY be out of sync by 3°F. Call for Service if this message does not disappear within a few minutes.

## **Sensors are out of sync – Call for service\* – M026\*\***

The temperature sensors ARE out of sync. The fault above has been established for at least 1 hour.

Call for Service.

## **Sensor a fault, sensor B fault – Sensor A: M031\*\*, Sensor B: M032\*\***

A temperature sensor or sensor circuit has failed. Call for Service.

## Other messages

### **Communication error**

The panel does not receive communication data from the system.

Customer service call required

### **Installed test software**

The controller is working in test software mode. Customer service call required.

### **° F or ° C is replaced by T °**

The control system is in test mode. Customer service call required.

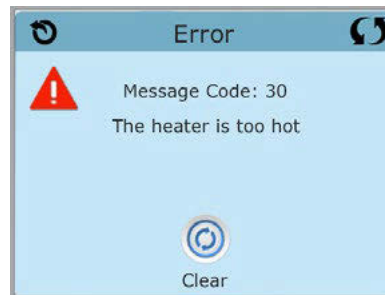

## 6.3.19 Error messages for the main system

### **Program memory failure\* - M022\*\***

At Power-Up, the system has failed the Program Checksum Test. This indicates a problem with the firmware (operation program) and requires a service call.

### **The settings have been reset (Persistent Memory Error)\* - M021\*\***

Contact your dealer or service organization if this message appears on more than one power-up.

\* Some messages can be reset from the panel. Messages that can be reset will appear with a "right arrow" at the end of the message. Press the message text to reset the message.

### **The clock has failed\* - M020\*\***

Contact your dealer or service organization.

### **Configuration error (Spa will not Start Up)**

Contact your dealer or service organization.

### **The GFCI test failed (System Could Not Test the GFCI) - M036\*\***

(North America Only) May indicate an unsafe installation. Contact your dealer or service organization.

### **A pump may be stuck on - M034 \*\***

Water may be overheated. **POWER DOWN THE SPA. DO NOT ENTER THE WATER.** Contact your dealer or service organization.

### **Hot fault - M035 \*\***

**A pump appears to have been stuck ON when spa was last powered**  
**POWER DOWN THE SPA. DO NOT ENTER THE WATER. Contact your dealer or service organization.**

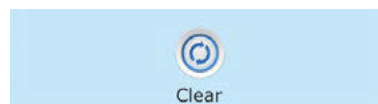

\*\* M0XX is a Message Code. Codes like this will be seen in the Fault Log

## 6.3.20 Reminder Messages

### General maintenance helps.

Reminder Messages can be suppressed by using the Preferences Menu. See Page 18. Reminder Messages can be chosen individually by the Manufacturer. They may be disabled entirely, or there may be a limited number of reminders on a specific model. The frequency of each reminder (i.e. 7 days) can be specified by the Manufacturer

### Check the pH

May appear on a regular schedule, i.e. every 7 days.

Check pH with a test kit and adjust pH with the appropriate chemicals.

### Check the sanitizer

May appear on a regular schedule, i.e. every 7 days.

Check sanitizer level and other water chemistry with a test kit and adjust with the appropriate chemicals.

### Clean the filter

May appear on a regular schedule, i.e. every 30 days.

Clean the filter media as instructed by the manufacturer. See HOLD on page 17.

### Test the GFCI (or RCD)

May appear on a regular schedule, i.e. every 30 days.

The GFCI or RCD is an important safety device and must be tested on a regular basis to verify its reliability. Every user should be trained to safely test the GFCI or RCD associated with the hot tub installation. A GFCI or RCD will have a TEST and RESET button on it that allows a user to verify proper function.

### Change the water

May appear on a regular schedule, i.e. every 90 days.

Change the water in the spa on regular basis to maintain proper chemical balance and sanitary conditions. Additional messages may appear on specific systems.

Reminder messages can be reset from the panel. Messages that can be reset will appear with a "right arrow" at the end of the message. Press the message text to reset the message. 240VAC, 60Hz, 40A, Class A GFCI-protected service (Circuit Breaker rating = 50A max.) 4 wires (Hot-Line 1, Hot-Line 2, Neutral, Ground). Additional messages may appear on specific systems.

### Clean the cover

May appear on a regular schedule, i.e. every 180 days.

Vinyl covers should be cleaned and conditioned for maximum life.

### Treat the wood

May appear on a regular schedule, i.e. every 180 days.

Wood skirting and furniture should be cleaned and conditioned per the manufacturers instructions for maximum life.



## Change the filter

May appear on a regular schedule, i.e. every 365 days.

Filters should be replaced occasionally to maintain proper spa function and sanitary conditions. Reminder messages can be reset from the panel. Messages that can be reset will appear with a "right arrow" at the end of the message. Press the message text to reset the message. Clean the filter

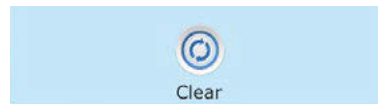

## Change the UV

May appear on a regular schedule. Change the UV as instructed by the manufacturer.

## Check ozone

May appear on a regular schedule. Check the ozone generator as instructed by the manufacturer.

## Service check-up

May appear on a regular schedule. Do a service check-up as instructed by the manufacturer

## 6.4 Audio System

The audio system consists of two tweeters and a subwoofer, they are mounted below the spa. The data is transmitted via Bluetooth z. B. from an iPhone to the receiver element, which is also mounted under the Whirlpool skirt. It is operated on Display of the spa.

Press the „Music“ button. It erschient the screen to operate the audio system. Press the „On“ button. The system searches now automatically coupled to an activated Bluetooth device,

Note: The system controller can only detect devices from the generation 4.

You can now receive Bluetooth music, press the screen to retrieve the feature. By pressing the „mode switching“ in the middle of the screen, connection via a fixed „Line In“ connection can be selected.

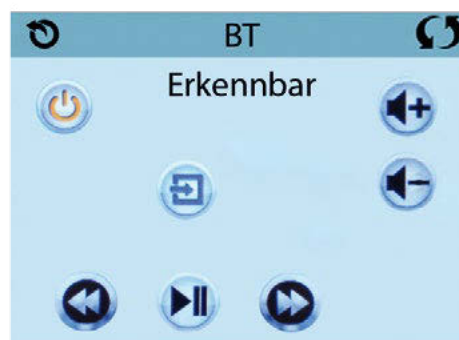

## 7. Care manual whirlpool covers

### 7.1 Care manual whirlpool covers

The cover one hot tub is designed for indoor and outdoor use. But even the best material and best processing are weather affected. Therefore, proper care should be exercised.

It can sometimes happen that the hardtop slightly discolors or gets lighter or darker. Disinfectant in the water can such cause changes. The function of the hardtop is not characterized affected. This is no reason for complaint. The care begins with the storage. Please store your hardtop in clean and well-ventilated areas. Vinyl can easily dry and become brittle.



*SpaCover vinyl care*

**Please clean the hardtop once a year according to the following recommendation, vinyl:**

- Place the hard top on a flat surface and inject it with a garden hose, so that the dirt can be removed. You can also work with a soft brush and warm soapy water. Are you going carefully so that vinyl is not damaged.
- Please use the Sunstar vinyl care or saddle soap as an additive for the cleaning water. Please do not use care products that the Vinyl attack.
- After washing, leave the hardtop dry well and rub it then a vinyl care or saddle soap.

**Warning:** Stubborn residues or slight discoloration of leaves please remove exclusively with benzene; then rub please the treated areas again with a vinyl conditioner.

**Remark:**

It can sometimes happens that the hardtop slightly discolored or lighter or darker. Disinfectant in water such changes cause. The function of the hardtop is not characterized impaired. This is no reason for complaint.

**Note for wind and weather covers:**

Please do not enter the cover and place objects on them. During heavy snow, please remove the snow completely to extend the high weight, the hardtop is not damaged. set If you take out for some reason the foam core, so please this is not the sun out. At higher temperatures, the foam melts.

## 7.2 Care of headrest and pillows

Headrests and neck pillows can remain in the pool below the cover. These are subjected to high humidity and water.

This can lead to accelerated wear and contamination. Therefore, headrests and covers should be taken out and stored dry when not using the spa. The covers should be regularly washed. Washing instructions are sewn into each cover.

**Note:** The covers are wearing parts that should be replaced over time.



### Material properties

**Material:** 100% polyester flame retardant (Trevira CS)

**Weight:** 370 g / m<sup>2</sup>

**Care:** 



**Washing:** 1%

**Dry cleaning:** 2%

**Abrasion resistance:** levels due to the tissue structure not relevant

**Pilling:** 5



## 7.3 Water maintenance

Thorough water maintenance forms the basis for a hygienic whirlpool. Clean and clear water is visually appealing and contributes considerably to the overall feeling of well being. Inadequate water maintenance can have an adverse effect on one's health. The following elements are essential components of good water maintenance.

**Filtration:** impurities which have dissolved in the water are mechanically being left behind in the filter.

**Flocculation:** Adding a flocculant to the water causes even the tiniest particles to bind, making them large enough to be filtered out.

**pH value:** Indicates when the water has reached an "equilibrium"; when bathing is at its most pleasant and disinfectants can work best.

**Disinfectant:** should be used to kill any germs.

**Adding fresh water:** The use of disinfectants can lead to salt deposits building up in the water. These should be kept as low as possible by adding fresh water.

### 7.3.1 Filtration

The filter should operate automatically for 6-8 hours per day. Besides servicing the filter regularly, the cartridges should be cleaned regularly as well.

The whirlpool's skim filter is fitted with very fine non woven filter cartridges which keep impurities out of the water. The cartridge itself is capable of lasting many years but should be changed every 12 months. A set of replacement cartridges is included in the delivery.

The filter cartridges should be cleaned at regular intervals (weekly or monthly, depending on how often the pool is used).

#### **The cartridges should be cleaned as follows:**

- Remove the skimmer lid.
- Pull out the skimmer basket.
- Unscrew the cartridges from the skim filter and rinse thoroughly inside and outside with a strong jet of water.
- To insert the cartridge, follow the steps in reverse. Make sure that the cartridge is correctly locked into position.

**Note:** A blocked filter can prevent the flow of water in the system and result in a reduced performance by the jets as well as a breakdown of the heating system.

### 7.3.2 Flocculation

Adding flocculation agents to the water helps the finest of impurities to bind so that they can be filtered and kept out of the whirlpool. Such tiny particles can be seen in the beam of the underwater light, where they appear as the smallest of bubbles. Where this is the case, a solid flocculation agent should be used in cartridge form so that it can be placed in the water or the skimmer basket. Do not use liquid flocculation agents, as it can be difficult to gauge the correct dosage.

### 7.3.3 pH Values

The pH-value in the whirlpool should be between 7.2 and 7.4. This is the ideal level for a disinfectant to work most efficiently and the water feels soft to the skin and is not corrosive. The strong addition of air when the massage jets are in use means that there can very quickly be a big increase in the pH value. It is therefore necessary to lower the pH manually. This is done by adding pH reducers, normally approx. 7 gr. per 1000 litres of water to reduce the pH value by 0.1. The pH value should be measured and regulated at least 1 x week.

### 7.3.4 Disinfection

The installed ozone generator supports the disinfection. If the pool is used daily by 2 persons an additional disinfection becomes necessary. Chlorine or oxygen should be used. For the correct concentration, follow the manufacturer's or product recommendations. In the case of inorganic chlorine, for example, 0.6 to 1 mg/l should be used. The disinfectant is best applied in the form of tablets which can be placed in the skimmer baskets.

**Notice:** The ozone generator switches off when the massage pumps are activated.

### 7.3.5 Adding fresh water, changing the water, emptying the whirlpool

Through the disinfection of the water in the whirlpool, salt deposits build up. To keep this build-up as low as possible, fresh water should be added.

This is why after every bath the whirlpool should be topped up to its normal level, 13 cm below the rim. A complete change of water should take place approximately every 8 weeks.

### 7.3.6 Cleaning and Maintenance of the surface

The surface of the pool is sanitary acrylic and the cabinet is made of smooth polyester, making it easy to clean. Marks should always be removed using plenty of lukewarm water and a soft sponge to avoid any scratches of the surface. Limestone and metal should be washed down with an acidic cleaner such as a mixture of vinegar and water.

Dirt and scum marks can be removed with lye. Care must always be taken, however, not to use foaming cleaning liquids, powders or creams on the acrylic surface of the whirlpool as any residue could bubble up when the whirlpool is in use.

Do not use cleaning agents in pressurized containers! Do not clean stainless steel with acidic products! Dull surfaces can be polished up so that they shine even after years. A special surface polish called „Poolfinish“ is available for just this purpose. This is applied with a soft cotton cloth and polished with gentle circular movements. Minor scratches can also be removed this way.

## 8. Instructions for bathing

- 8.1 Water temperature** Water temperatures in whirlpools are significantly higher than those for instance of swimming pools. This is so, because it is through the combination of heat and the movement of the water that the desired feeling of relaxation can be achieved. However, this may cause increased pressure on the circulation. Therefore, in order to ensure safe bathing, always observe the following rules and follow these instructions for water maintenance. The water temperature should be set at approximately 36° C. Higher temperatures can cause circulatory problems and lead to fatigue - lower temperatures of, for example 32°-33° C have an invigorating and refreshing effect. The ideal temperature will naturally depend on the constitution of each individual.
- 8.2 Duration of baths** The higher the temperature of the water, the less time should be spent in the water. If the water is 36° C the bathing time should be approximately 20 minutes, if the water is 38° C, no more than 10-12 minutes.
- 8.3 Taking a break** Each bath should be followed by a cool-down period of the same length of time. This can be done either by going out into the fresh air or by taking a swim in a cool pool.
- 8.4 Showering before bathing** Before entering the whirlpool, be sure to shower thoroughly. Otherwise the high temperature of the water means that impurities in the water will have to be treated with correspondingly high amounts of disinfectant.
- 8.5 Sauna and Whirlpool** The combination of sauna and whirlpool is only recommended for people whose constitution can really tolerate it. In any event, it is important to include a cooling off period between baths.
- 8.6 To be avoided** Never bathe after consuming alcohol, immediately after meals, with cold or flu symptoms and in no circumstances if suffering from a heart condition.
- 8.7 Bath salts, oils or foams** Bath salts, oils or foams should never be used in a whirlpool. These can cause excessive foaming or remain in the pipes and jets and pollute them.

## 9. Schematics

Platine  
BP2100G1 – PN 56389 – 02

Switch control BP2100 from 230V to 3 x 230 V

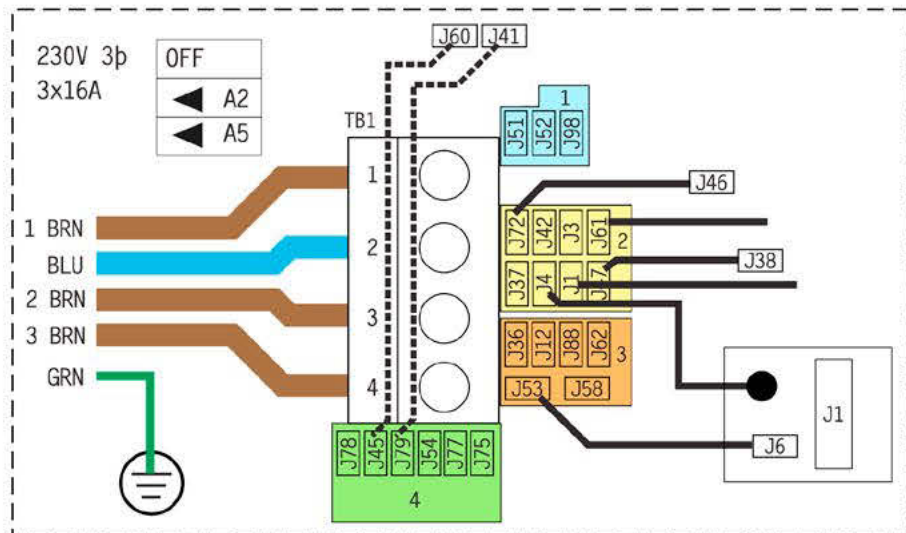
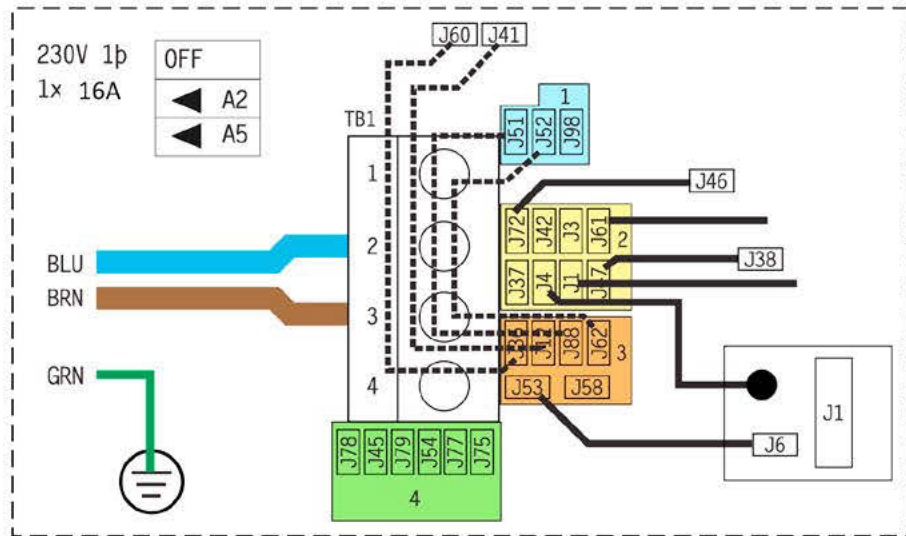

All pins in the coloured areas are linked together. Thus it does not matter if the pin J79, J78 or J77 in the green area is used.

To switch to 400 V remove the both connections between blue and brown area and connect J60 and J41 to the green area.

**Platine**  
**BP2100G1 – PN 56389 – 02**

**Connection points**

**Board Connector Key**

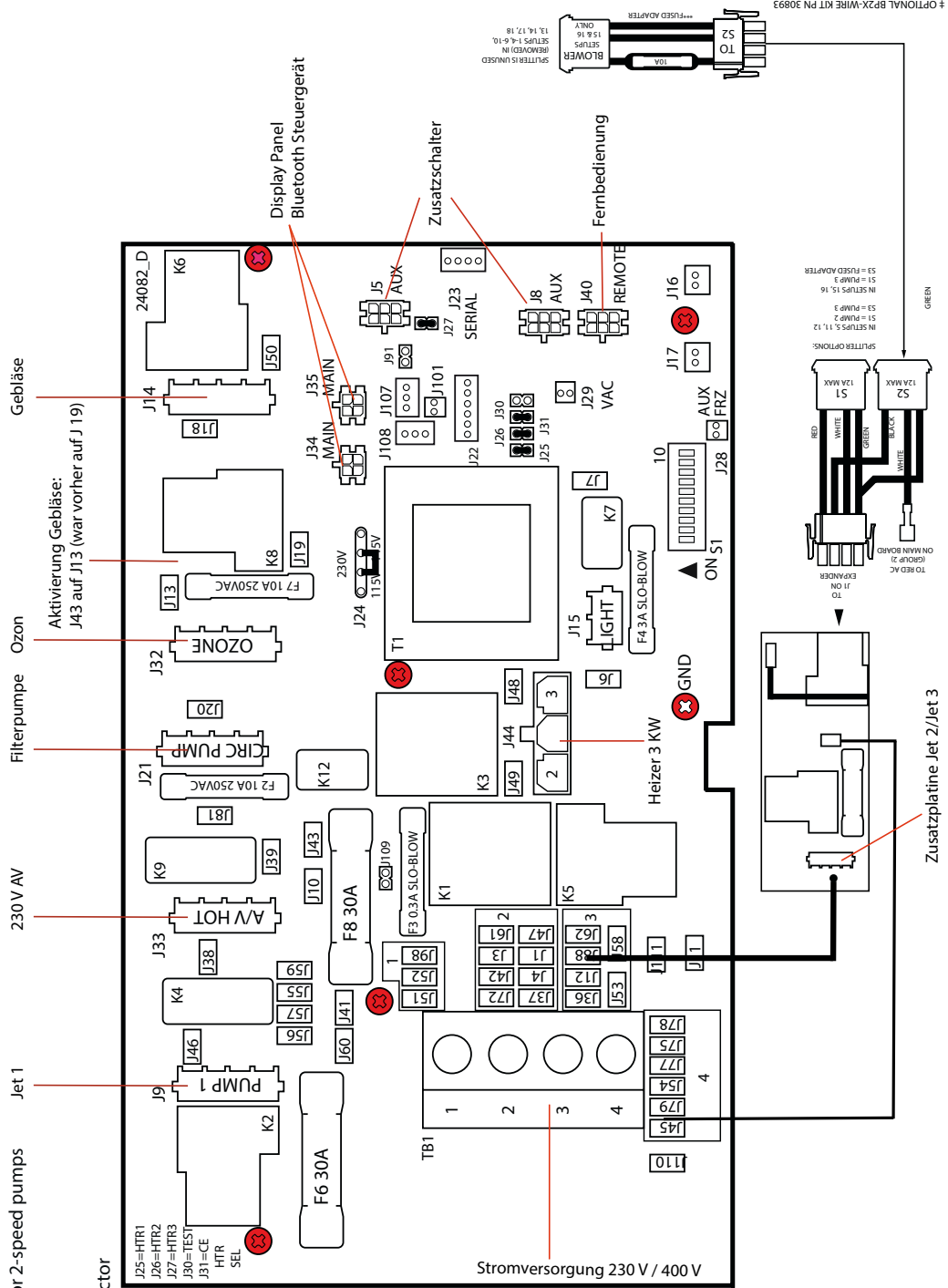

## 10. Checklist for the supply of hot tubs

Customer was sent :	Yes	No
<b>1. Filling and emptying of the pool</b>		
• Check drain valves and gate valves open/close and are working	<input type="checkbox"/>	<input type="checkbox"/>
• Air locks have been cleared	<input type="checkbox"/>	<input type="checkbox"/>
• Priming mode has been selected	<input type="checkbox"/>	<input type="checkbox"/>
<b>2. Operation of the display</b>		
• Call functions	<input type="checkbox"/>	<input type="checkbox"/>
• Set time and Filter-cycle	<input type="checkbox"/>	<input type="checkbox"/>
• Cleaning cycles, etc.	<input type="checkbox"/>	<input type="checkbox"/>
<b>3. Water Care</b>		
• Wash through and clean the cartridge every 1-4 weeks	<input type="checkbox"/>	<input type="checkbox"/>
• Change the cartridge every 12 months	<input type="checkbox"/>	<input type="checkbox"/>
• Water change every 3 months	<input type="checkbox"/>	<input type="checkbox"/>
• Injectors can calcify - check and clean	<input type="checkbox"/>	<input type="checkbox"/>
• Ozonator is a consumable check its operation	<input type="checkbox"/>	<input type="checkbox"/>
<b>4. Cover</b>		
• Covers have a finite life	<input type="checkbox"/>	<input type="checkbox"/>
• Regular cleaning and maintenance with specified care products	<input type="checkbox"/>	<input type="checkbox"/>
<b>5. Resysta</b>		
• Removal of water stains with a soft brush	<input type="checkbox"/>	<input type="checkbox"/>
• possibly refresh the color	<input type="checkbox"/>	<input type="checkbox"/>
<b>6. Headrests</b>		
• Remove and clean	<input type="checkbox"/>	<input type="checkbox"/>
• Wash headrest covers	<input type="checkbox"/>	<input type="checkbox"/>
• Refit covers and position headrests	<input type="checkbox"/>	<input type="checkbox"/>
<b>7. Electricity</b>		
• Is the terminal fixed down?	<input type="checkbox"/>	<input type="checkbox"/>

*Have fun with your new Riviera Spa!*

Customer Signature \_\_\_\_\_

Dated: \_\_\_\_\_

Trade Signature \_\_\_\_\_

Dated: \_\_\_\_\_



**RivieraPool®**

**One of the leading  
German manufacturers  
of prefabricated  
swimmingpools,  
pool equipment and  
whirlpools.  
Member in the BSW.**



**[www.rivierapool.com](http://www.rivierapool.com)**

Date: 10.08.16